

ITEM NO.	DESCRIPTION	LENGTH	QTY.	ANGLE1	ANGLE2
1			1		
2	TUBE, SQUARE 2.00 X 2.00 X .25	2.9	1	0.00	0.00
3	TUBE, SQUARE 2.00 X 2.00 X .25	3.35	2	30.00	15.00
4	TUBE, SQUARE 2.00 X 2.00 X .25	4.02	1	0.00	0.00
5	TUBE, SQUARE 2.00 X 2.00 X .25	5.27	2	15.00	0.00
6	TUBE, SQUARE 2.00 X 2.00 X .25	9	1	0.00	0.00
7	TUBE, SQUARE 2.00 X 2.00 X .25	11.47	1	30.00	30.00

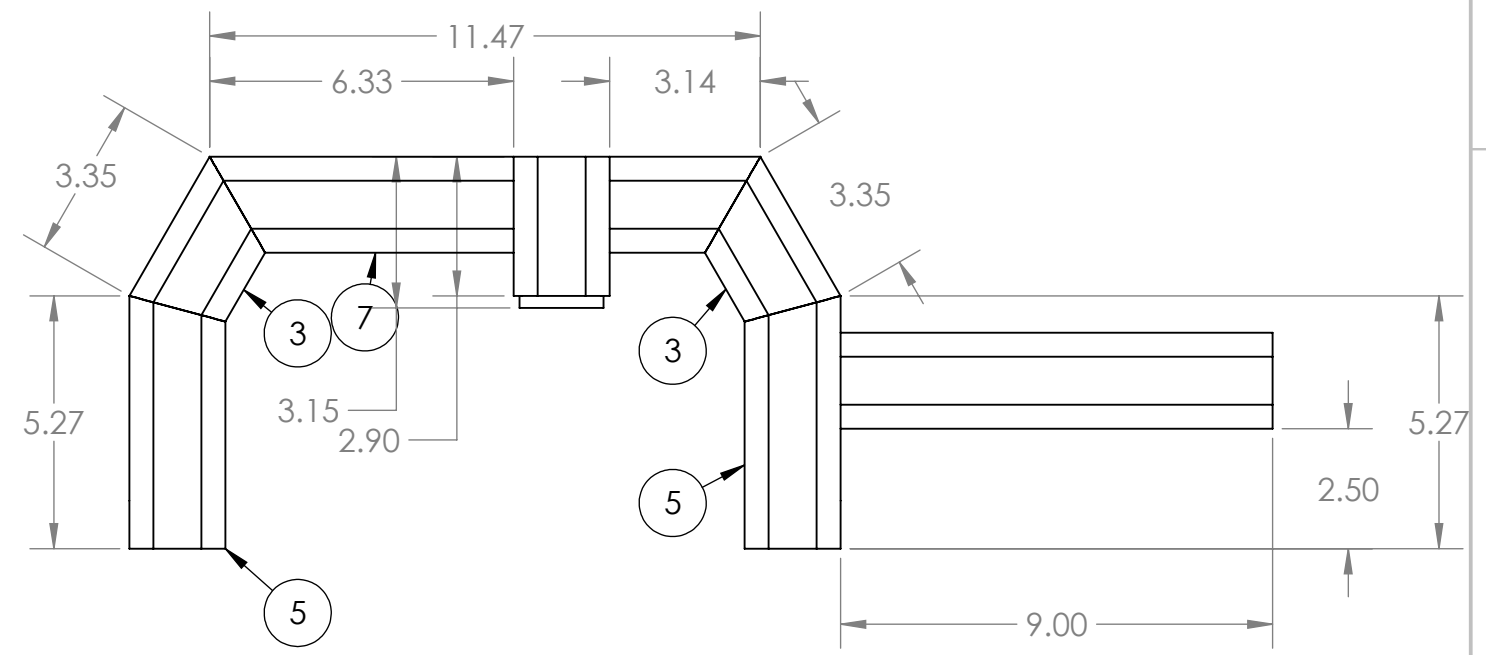
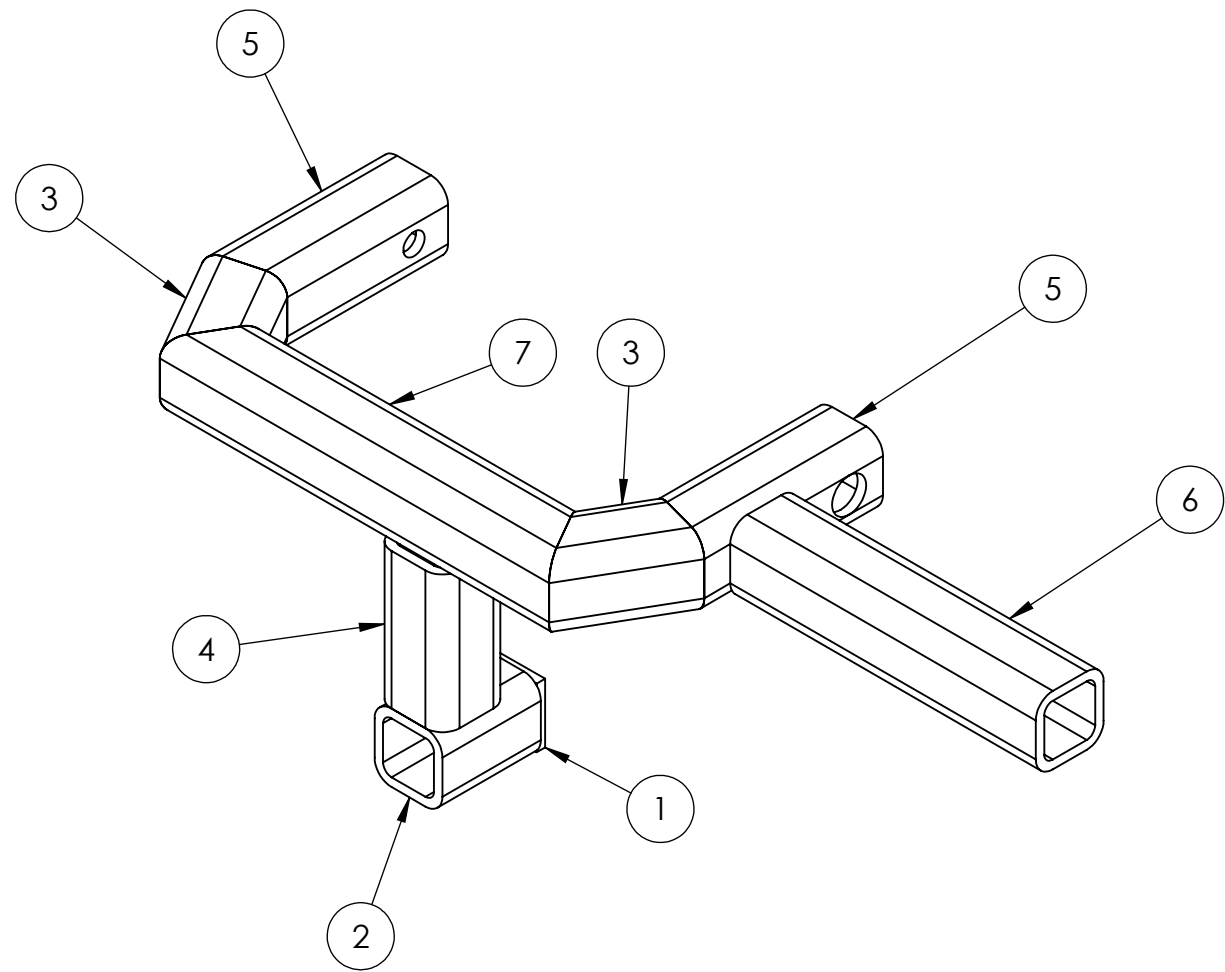
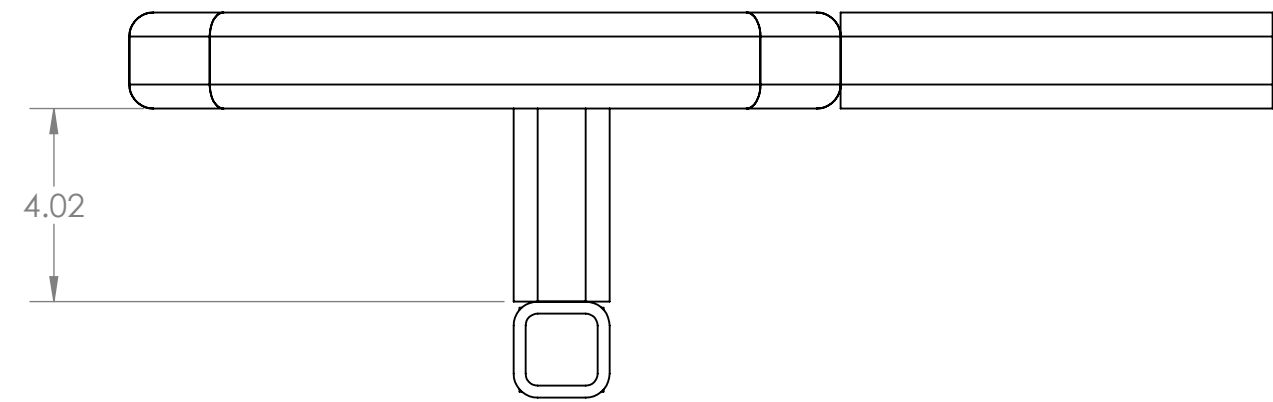

PROPRIETARY AND CONFIDENTIAL
 THE INFORMATION CONTAINED IN THIS
 DRAWING IS THE SOLE PROPERTY OF
 <INSERT COMPANY NAME HERE>. ANY
 REPRODUCTION IN PART OR AS A WHOLE
 WITHOUT THE WRITTEN PERMISSION OF
 <INSERT COMPANY NAME HERE> IS
 PROHIBITED.

		UNLESS OTHERWISE SPECIFIED:	NAME	DATE	TITLE:
		DIMENSIONS ARE IN INCHES	DRAWN		
		TOLERANCES:	CHECKED		
		FRACTIONAL ±	ENG APPR.		
		ANGULAR: MACH ± BEND ±	MFG APPR.		SIZE DWG. NO. REV
		TWO PLACE DECIMAL ±	Q.A.		
		THREE PLACE DECIMAL ±	COMMENTS:		
NEXT ASSY	USED ON	MATERIAL			
APPLICATION		FINISH			
		DO NOT SCALE DRAWING			
			SCALE: 1:4 WEIGHT:		SHEET 1 OF 2

B Trans Fixture

4

3

2

1

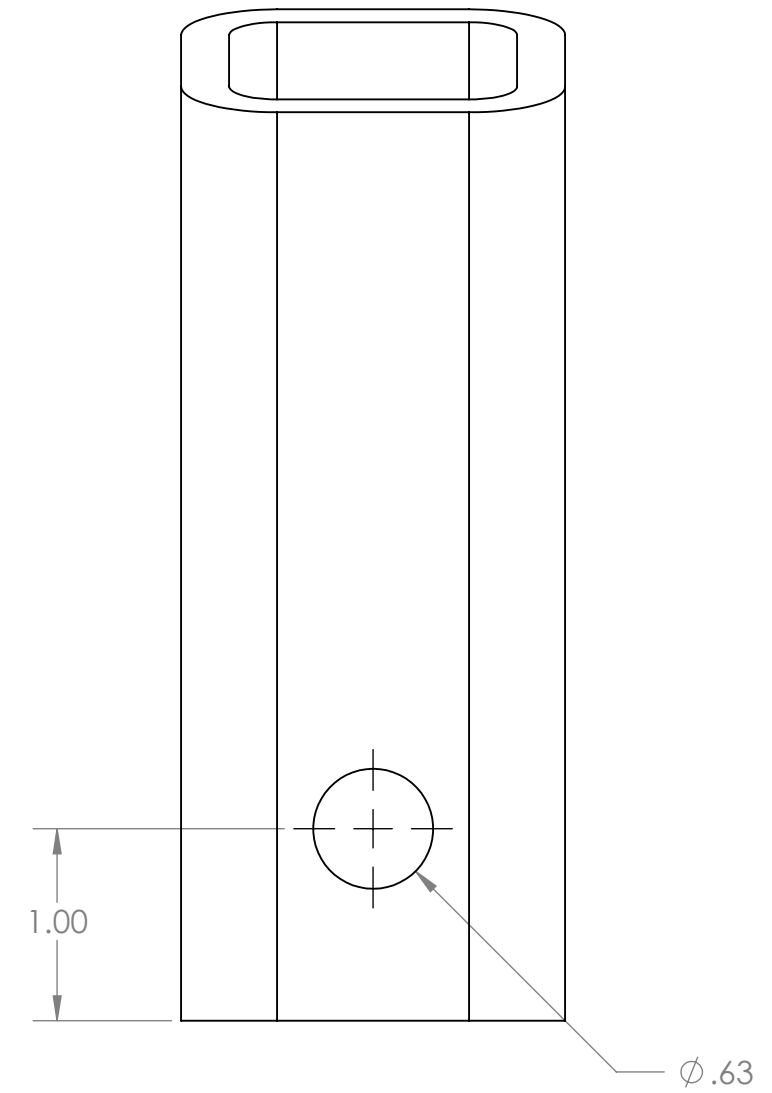
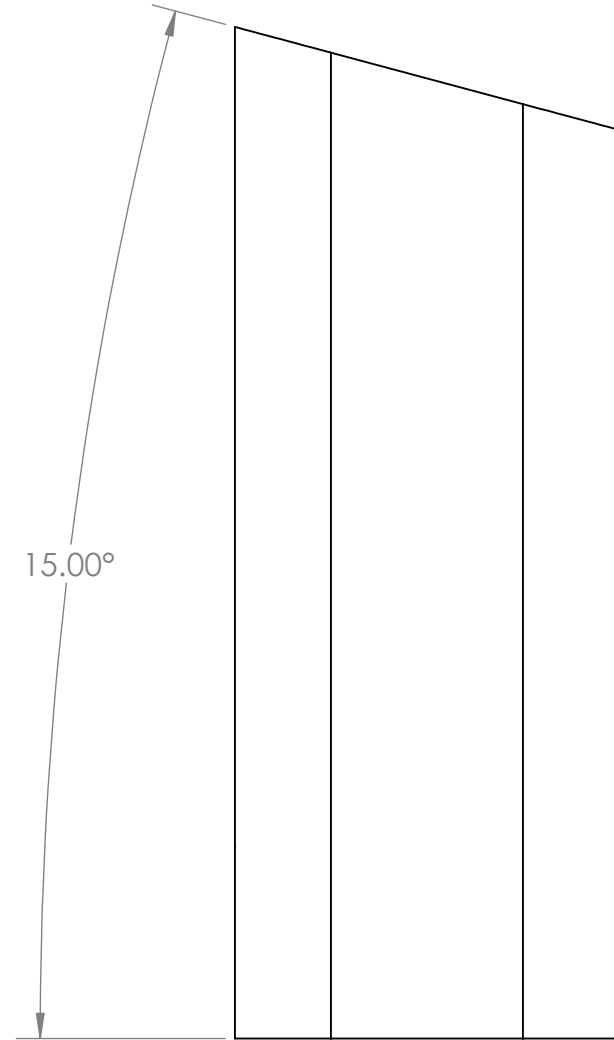
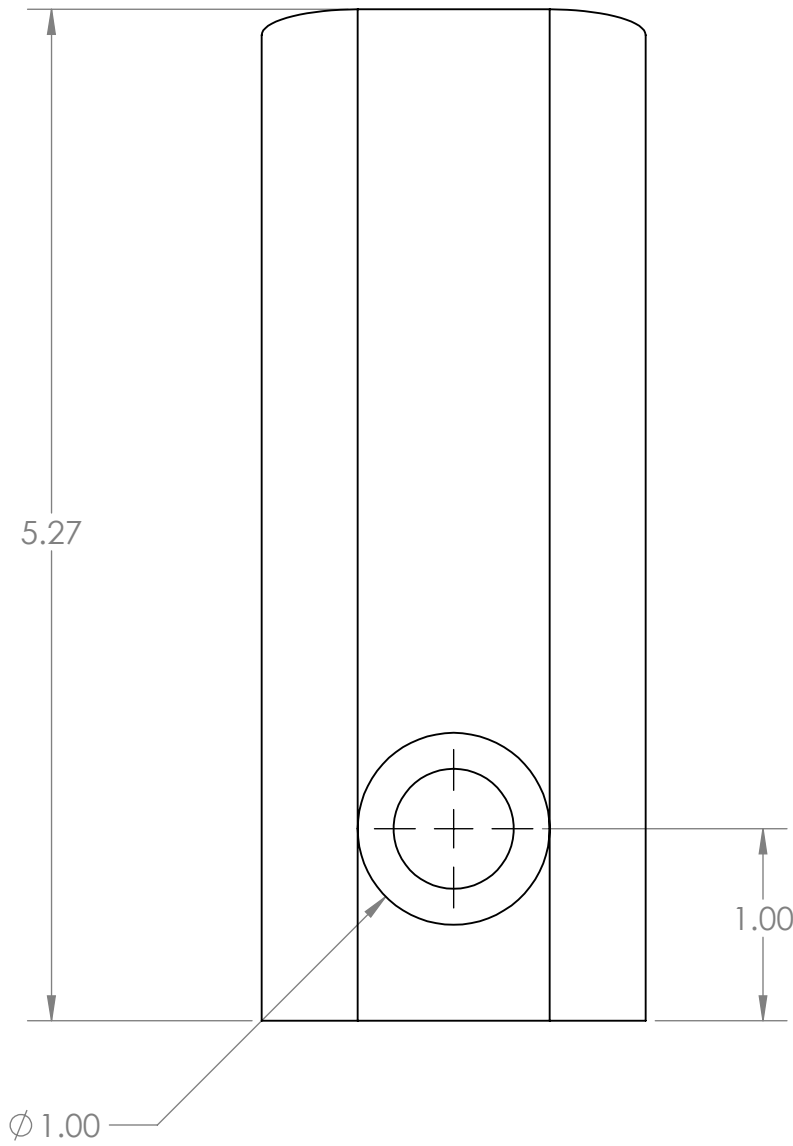

B

B

A

A

PROPRIETARY AND CONFIDENTIAL
 THE INFORMATION CONTAINED IN THIS
 DRAWING IS THE SOLE PROPERTY OF
 <INSERT COMPANY NAME HERE>. ANY
 REPRODUCTION IN PART OR AS A WHOLE
 WITHOUT THE WRITTEN PERMISSION OF
 <INSERT COMPANY NAME HERE> IS
 PROHIBITED.

		UNLESS OTHERWISE SPECIFIED:	NAME	DATE	TITLE:
		DIMENSIONS ARE IN INCHES	DRAWN		
		TOLERANCES: FRACTIONAL ±	CHECKED		
		ANGULAR: MACH ± BEND ± TWO PLACE DECIMAL ± THREE PLACE DECIMAL ±	ENG APPR.		
		INTERPRET GEOMETRIC TOLERANCING PER:	MFG APPR.		SIZE DWG. NO. REV
		MATERIAL	Q.A.		
NEXT ASSY	USED ON	FINISH	COMMENTS:		SCALE: 1:1 WEIGHT: SHEET 2 OF 2
APPLICATION		DO NOT SCALE DRAWING			

B Trans Fixture

4

3

2

1