

BODY CONTROL SYSTEM

Fig. 2: Identifying Body Control Module (BCM) - C1 Connector Terminals
GENERAL MOTORS CORP.
 2002 Chevrolet Silverado 3500

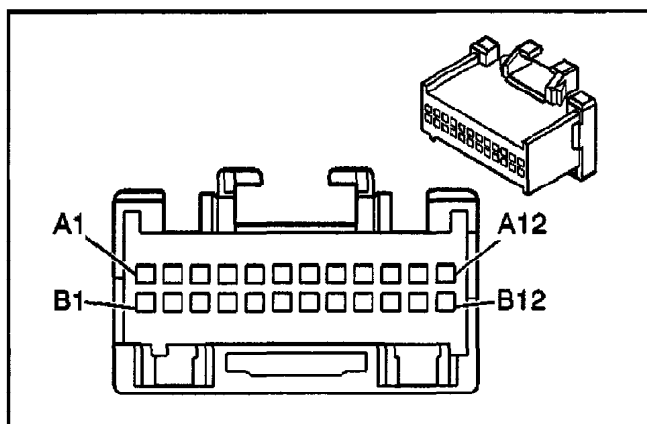

Connector Part Information		<ul style="list-style-type: none"> • 12160778 • 24-Way F Micro-Pack 100 Series (BRN) 	
Pin	Wire Color	Circuit No.	Function
A1	BLK	1850	Ground
A2	ORN	1140	Battery Positive Voltage
A3	WHT	194	Door Unlock Control
A4	LT BLU	195	Door Lock Control
A5	BRN	1295	Variable Effort Steering Actuator Control
A6	—	—	Not Used
A7	BLK	755	RAP Relay Coil Control
A8	DK BLU	1393	Inadvertent Power Relay Control
A9	BLK	28	Horn Relay Control
A10	—	—	Not Used
A11	LT GRN/ BLK	592	DRL Relay Control
A12	LT GRN	1037	BCM Class 2 Serial Data
B1	BLK	1850	Ground
B2	PNK	39	Ignition 1 Voltage
B3	RED/WHT	812	12 Volt Reference
B4	ORN	461	GMCM Serial Data
B5	GRY	705	5 Volt Reference
B6	LT BLU	14	Left Turn Signal Lamps Supply Voltage
B7	DK BLU	15	Right Turn Signal Lamps Supply Voltage
B9	BRN	41	Ignition 3 Voltage
B10	LT BLU	1134	Park Brake Switch Signal
B11	BLK/WHT	238	Seatbelt Switch - Left
B12	LT BLU	553	Tow/Haul Switch Signal

G01713628