

INSTALLATION INSTRUCTIONS 3³/₈" & 5" ELECTRIC SPEEDOMETER

2650-1164-00 Rev. A



QUESTIONS:

If after completely reading these instructions you have questions regarding the operation or installation of your instrument(s), please contact Auto Meter Technical Service at **815-899-0801**. You may also email us at service@autometer.com.

Additional information can also be found at http://www.autometer.com/tech_faq.aspx

General Information

This electric speedometer utilizes a LCD to display odometer and trip odometer mileage. Momentarily pressing of the Trip/Reset button on the dial window toggles the odometer/trip odometer information displayed on the LCD. Pressing the button, while in trip mode, for more than two seconds will reset the trip odometer. The odometer cannot be reset.

(Speedometers are pre-calibrated for 16 pulse/revolution sender. Speedometers that include a 2 wire sender are pre-calibrated to 8 pulse/revolution to match sender. See Speedo Senders below for available Auto Meter Senders.) The speedometer should be calibrated to ensure accurate operation after installation.

NOTE: The odometer on this speedometer will read from 1 to 5 miles. This is done during factory testing to insure optimum quality.

Speedometer Senders

The speedometer is designed to operate with an electrical speed sender. The speed senders signal pulse range must be between 500 and 400,000 pulses/mile. Any speed sender or electronic module that meets the following two conditions can be used:

- Pulse range generated proportional to the vehicle speed
- Output within the voltage ranges listed below:

2.0 to 16V peak (Square Wave), 3 wire
2.0 to 120V peak to peak (Sine Wave), 2 wire

Recommended Auto Meter Hall-Effect (Square Wave), 3 wire, 16 Pulses Per Revolution senders:

5291 Standard 7/8-18 thread
5292 Ford, plug in

Mounting

1. Mount a 3³/₈" speedometer in a 3³/₈" dia. hole and a 5" speedometer in a 4³/₈" dia. hole in the dashboard. (be careful not to make the hole too large.)
2. Cut a ³/₈" dia. hole in the firewall for the speedometer wires. Place a rubber grommet in the hole and route the connector wires through the grommet to the engine compartment.
3. Connect the speedometer wires as shown in the wiring section.
4. Secure the speedometer to the dashboard using the provided bracket, and hardware.

Note: With the ignition switch off, the speedometer pointer may not always rest at zero. This is normal. When engine is started, the pointer will first move to half scale then will rest at zero.

WARNING

Incorrect hookup will damage the speedometer and void warranty. Please read these instructions carefully.

CAUTION!

As a safety precaution, the power wire to this product should be fused before connecting it to the positive (+) side of the 12 VDC battery. We recommend using a 4 Amp, 3 AG fast-acting type cartridge fuse (Littlefuse® #312 004 or an equivalent) inline with the power wire to our product.

3³/₈" Models

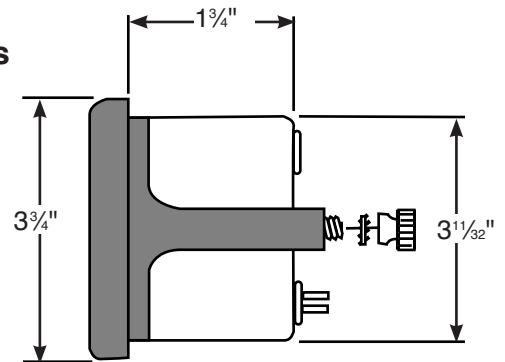

5" Models

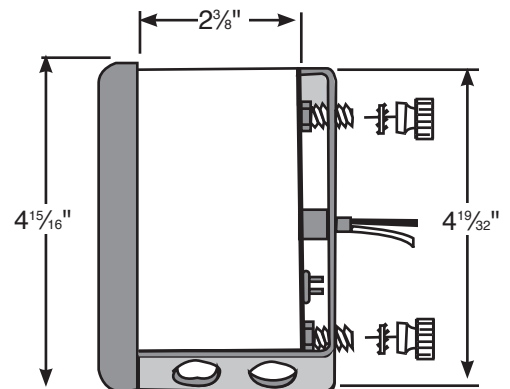

Once the speedometer is mounted and wired into the vehicle, the speedometer should be tested to verify the electrical connections are working properly. First, watch the speedometer's pointer as the power is applied. The pointer should first move to a midrange position, then down to the zero box on the dial. This action verifies that power is properly connected to the speedometer. The vehicle should be driven some distance to verify the Vehicles Speed Sender (VSS) is connected properly, and that the pointer moves. If the pointer does not move off the zero box, verify the VSS is connected properly.

Calibration

To calibrate your electronic speedometer:

- 1) With the power off, push and hold the calibration button (trip/reset button when equipped). While holding the button, start the vehicle and continue to hold the button until the pointer sweeps to full scale and stays at full scale. You may now release the button.
- 2) Drive to the beginning of a pre-marked 2 mile distance and come to a stop. It does not matter how far away it is to get to this pre-marked 2 mile distance. Do NOT shut the engine off. Push and release the button. The pointer will drop to half scale.

- 3) Drive the 2 mile distance. The pointer will remain at the half scale mark no matter what speed you drive. If the speedometer has a LCD display odometer, it will be normal to see it counting rapidly as it is receiving a speed signal. If you have to stop during the calibration, that is o.k. The speedometer is simply counting pulses during this time.
- 4) At the end of the 2 mile distance, come to a complete stop and push and release the button. The pointer will drop to 0 and the calibration is stored.

You are now finished with calibrating.

Wiring

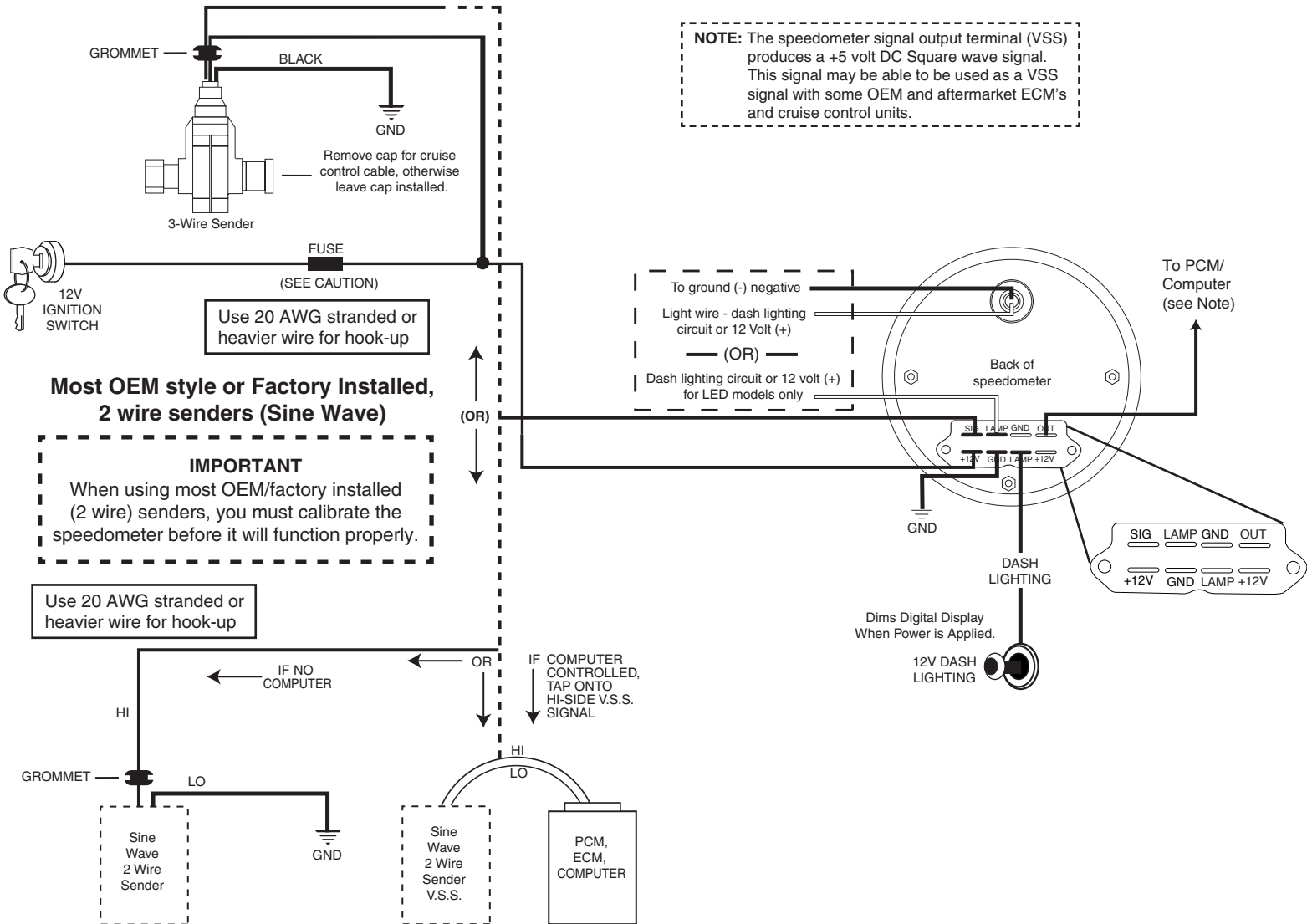

SERVICE

For service send your product to Auto Meter in a well packed shipping carton. Please include a note explaining what the problem is along with your phone number. Please specify when you need the product back. If you need it back immediately mark the outside of the box "RUSH REPAIR," and Auto Meter will service product within two days after receiving it. (\$10.00 charge will be added to the cost of "RUSH REPAIR.") If you are sending product back for Warranty adjustment, you must include a copy (or original) of your sales receipt from the place of purchase.

12 MONTH LIMITED WARRANTY

Auto Meter Products, Inc. warrants to the consumer that all Auto Meter High Performance products will be free from defects in material and workmanship for a period of twelve (12) months from date of the original purchase. Products that fail within this 12 month warranty period will be repaired or replaced at Auto Meter's option to the consumer, when it is determined by Auto Meter Products, Inc. that the product failed due to defects in material or workmanship. This warranty is limited to the repair or replacement of parts in the Auto Meter instruments. In no event shall this warranty exceed the original purchase price of the Auto Meter instruments nor shall Auto Meter Products, Inc. be responsible for special, incidental or consequential damages or costs incurred due to the failure of this product. Warranty claims to Auto Meter must be transportation prepaid and accompanied with dated proof of purchase. This warranty applies only to the original purchaser of product and is non-transferable. All implied warranties shall be limited in duration to the said 12 month warranty period. Breaking the instrument seal, improper use or installation, accident, water damage, abuse, unauthorized repairs or alterations voids this warranty. Auto Meter Products, Inc. disclaims any liability for consequential damages due to breach of any written or implied warranty on all products manufactured by Auto Meter.

FOR SERVICE SEND TO: AUTO METER PRODUCTS, INC. 413 W. Elm St., Sycamore, IL 60178 USA (815) 899-0801
 Email us at service@autometer.com