

1998 Dodge Durango  
Tach Adapter for GM Gen 3 V8

Adapter source: [http://www.bakerelectronic.com/products\\_tsd/](http://www.bakerelectronic.com/products_tsd/)

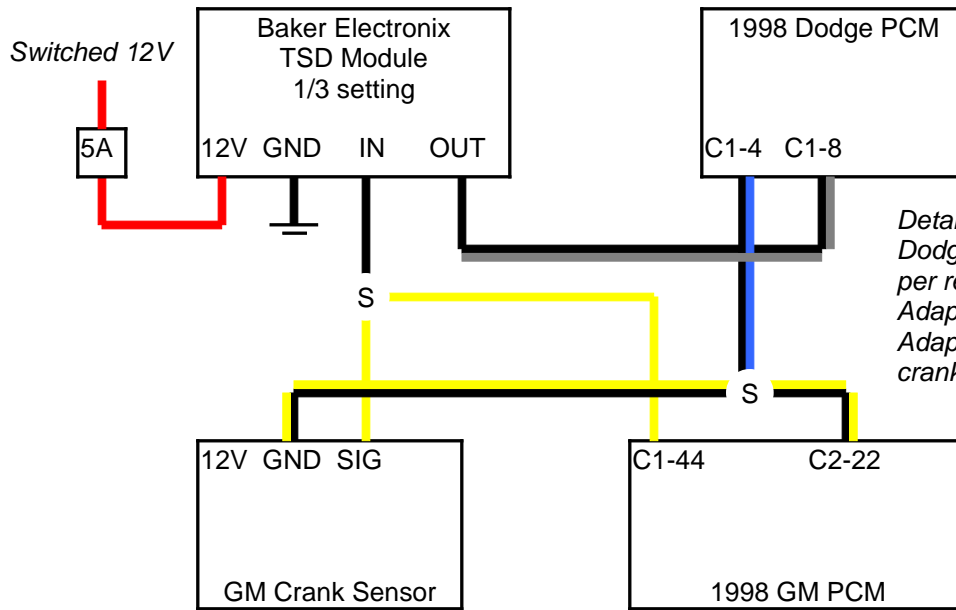

**UNTESTED  
THEORY**

*Details:  
Dodge crank sensor is 8 pulses  
per revolution. GM is 24 PPR.  
Adapter reduces pulses to 1/3.  
Adapter is spliced in using GM  
crank sensor.*