

Power Distribution Schematics (Battery, ABS BAT-1 and COOL FAN Fuses)

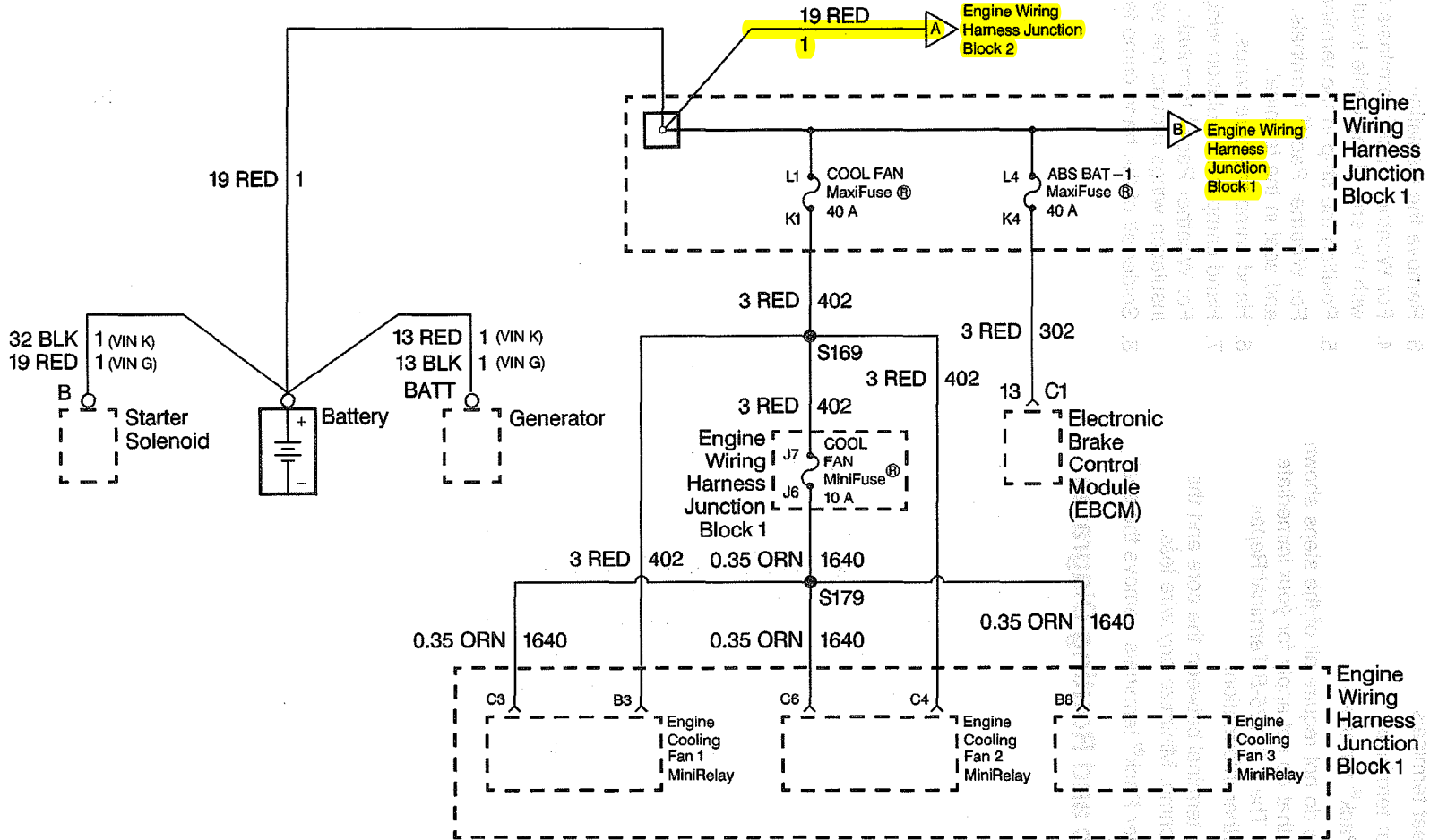

LOC



Power Distribution Schematics (Fusible Links, CIG/ACCY, ENG CTRL, IGN, I/P-1, I/P-2, and PWR ACCY Fuses)

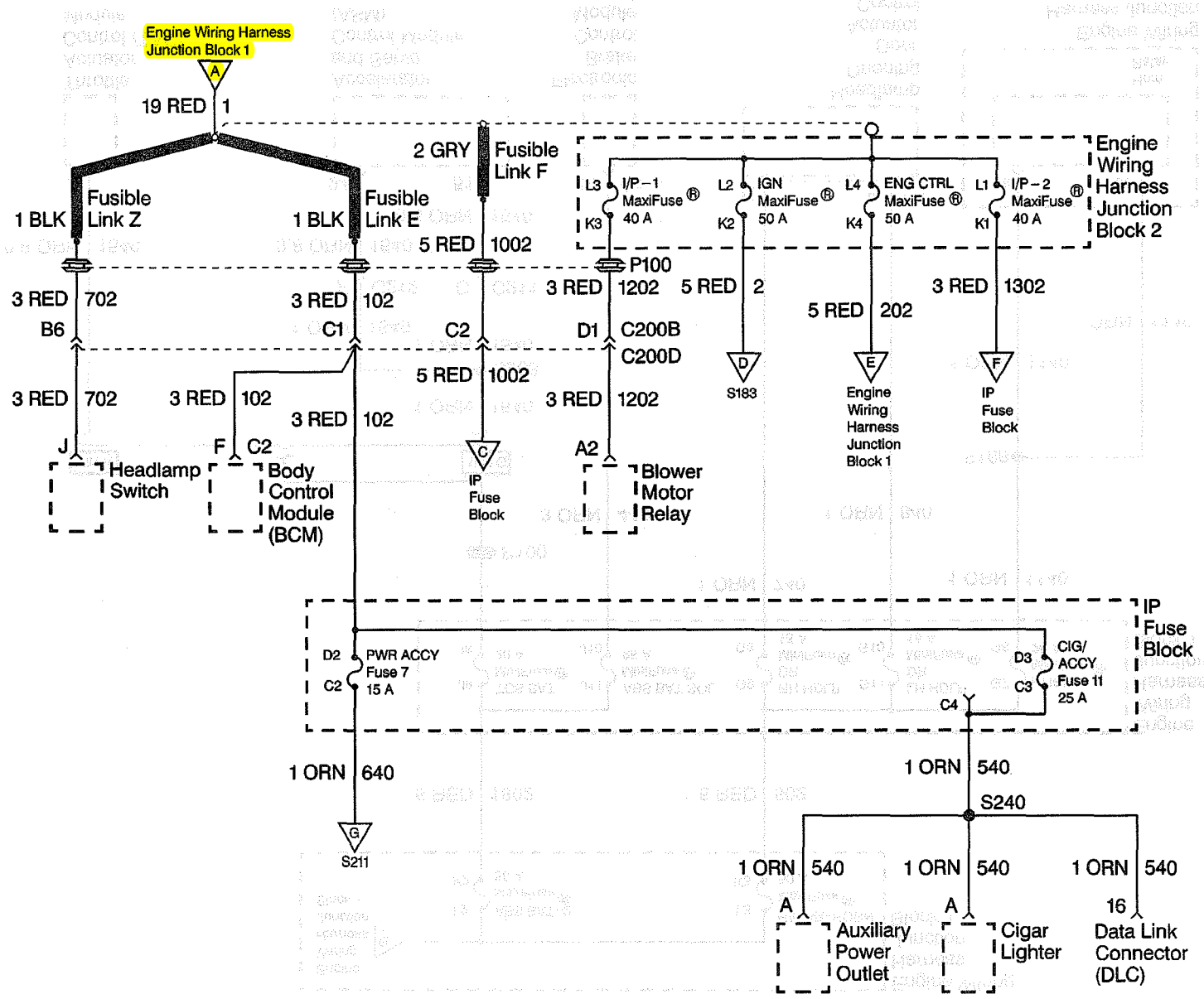

LOC



Ground Distribution Schematics (G100, G101, G102, G109, G111, G202)

