

**Oil Pump, Pump Screen and Deflector Replacement  
Removal Procedure**

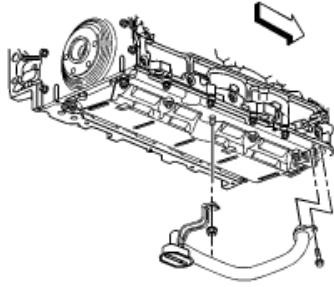

1. Remove the engine front cover.
2. Remove the engine [oil pan](#).
3. Remove the oil pump screen bolt and nut.
4. Remove the oil pump screen and O-ring seal.
5. Remove the O-ring seal from the pump screen.
6. Discard the O-ring seal.

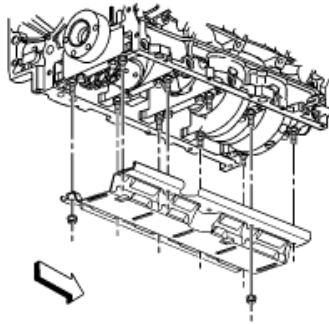

7. Remove the remaining [crankshaft](#) oil deflector nuts.
8. Remove the [crankshaft](#) oil deflector.

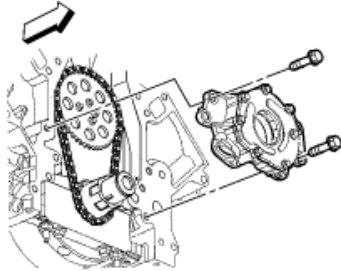

9. Remove the oil pump bolts. **Important:** Do not allow dirt or debris to enter the oil pump, cap the ends as necessary.
10. Remove the oil pump.
11. Clean and inspect the oil pump. Refer to Oil Pump Cleaning and Inspection.

#### Installation Procedure

**Important:** Inspect the engine block oil gallery passages. These surfaces must be clear and free of debris or restrictions.

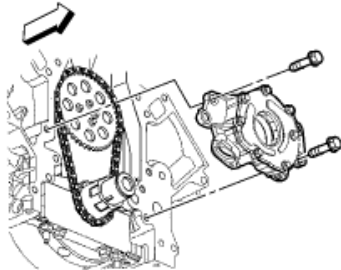

1. Align the splined surfaces of the crankshaft sprocket and the oil pump drive gear and install the oil pump.
2. Install the oil pump onto the crankshaft sprocket until the pump housing contacts the face of the engine block. **Notice:** Refer to Fastener Notice in Service Precautions.
3. Install the oil pump bolts. Tighten the oil pump bolts to **25 Nm (18 ft. lbs.)**.

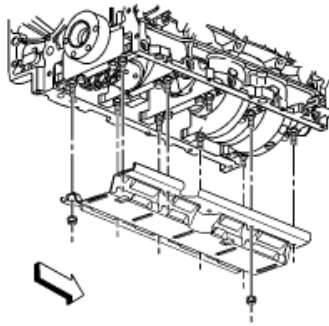

4. Install the crankshaft oil deflector.
5. Install the crankshaft oil deflector nuts. Tighten the crankshaft oil deflector nuts to **25 Nm (18 ft. lbs.)**.

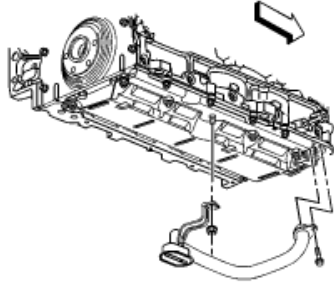

- 
6. Lubricate a NEW oil pump screen O-ring seal with clean engine oil.
  7. Install the NEW O-ring seal onto the oil pump screen. **Important:** Push the oil pump screen tube completely into the oil pump prior to tightening the bolt. Do not allow the bolt to pull the tube into the pump. Align the oil pump screen brackets with the correct **crankshaft** bearing cap studs.
  8. Install the oil pump screen.
  9. Install the oil pump screen bolt and nut.
    - Tighten the oil pump screen bolt to **12 Nm (106 inch lbs.)**.
    - Tighten the oil pump screen nut to **25 Nm (18 ft. lbs.)**.
  10. Install the engine **oil pan**.
  11. Install the engine front cover.