

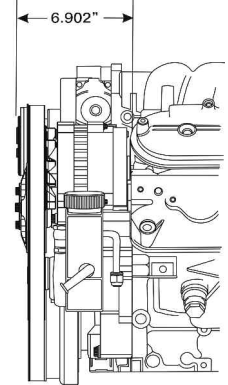

FRONT RUNNER - GM LS Engines

LS CHEVY (GM) FRONT RUNNER™ ENGINE DRIVE SYSTEM

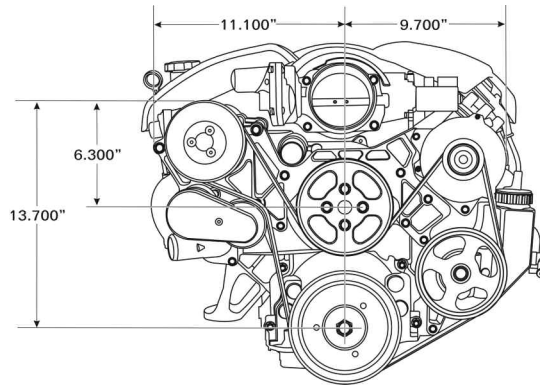

MEASUREMENTS ARE FROM FACE OF BLOCK

LS Chevy Front Runner™ Drive System Includes:

- Main Truss Mounting Bracket
- ATI Harmonic Balancer
- Power Steering Pump Bracket
- Hi-Perf Aluminum Water Pump
- ARP Polished Stainless Hardware
- Sanden SD7 Compressor With Formed Aluminum Hardlines
- 140 Amp Alternator
- Compressor Clutch Cover
- Tensioner Cover
- Crankshaft Pulley
- Water Pump Pulley
- Power Steering Pump Pulley (With Power Steering Kit)
- Dayco Perf Serpentine Drive Belt
- Dayco OEM Tensioner
- Delphi-Saginaw Power Steering Pump With Integral Reservoir



Bright LS Chevy Front Runner™ Drive System

- 174014 With Power Steering (includes Pump)
- 174016 With Power Steering (less Power Steering Pump)
- 175015 Non-Power Steering

Black Hardcoat LS Chevy Front Runner™ Drive System

- 174011 With Power Steering (Includes Pump)
- 174017 With Power Steering (Less Power Steering Pump)
- 175011 Non-Power Steering

**Hardcoat kits include black hardcoated pulleys and black anodized bracket, clutch & tensioner covers*

Bright LS7 Chevy Front Runner™ Drive System

- 174012 With Power Steering (Includes Pump)
- 174019 With Power Steering (Less Power Steering Pump)
- 175012 Non-Power Steering

Black Hardcoat LS7 Chevy Front Runner™ Drive System

- 174013 With Power Steering (Includes Pump)
- 174018 With Power Steering (Less Power Steering Pump)
- 175013 Non-Power Steering

**Hardcoat kits include black hardcoated pulleys and black anodized bracket, clutch and tensioner covers*

Front Runner
Accessories Page 62

New! L92 Spacer Kit.
Also for variable timing engines. **176005**

CUSTOMER SERVICE TEAM

Roy Arreguin is one of our sales team members. Roy worked as an engineer for over 25 years and has built and restored many hot rods and classic cars as a hobby, with his pride and joy being a 1940 Ford Deluxe coupe.

