

MF01-021  
061892

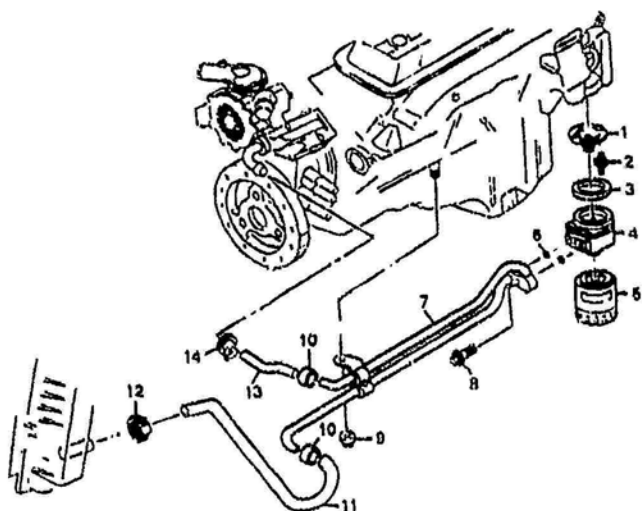

MF01-021

1993-1994 F ENGINE OIL COOLER LINES (KC4)

1.	2-C6	1.840	ADAPTER, OIL FLTR	93-94	F (LT1, KC4)	1	10055722
2.	2-C6	1.840	STUD, OIL FLTR ADAP (5/16-18X1.88)	93-94	F (LT1, KC4)	2	14101106
		8.900	BOLT, HEX WA HD (.312-18X1.125 PL) (OIL FLTR ADAP)	93-94	F	2	3951644
3.	2-B26	1.550	SEAL, ENG OIL CLR	93-94	F (LT1)	1	14067566
4.	2-B26	1.540	COOLER, ENG OIL	93-94	F (LT1, KC4)	1	10168415
5.	2-C5	1.836	FILTER, OIL (AC-DELCO #PF25)	93-94	F	1	6438261
6.	2-B26	1.540	WASHER, ENG OIL CLR (PART OF 7)	93-94	F	2	10170112
7.	2-B26	1.540	HOSE, ENG OIL CLR (INCLS 6, 10, 11, 13)	93-94	F (KC4)	1	10241617
8.		6.900	BOLT, HFH M10X1.5X30 10.9 FL BLK 21.5 OD 26MM THD POINTED (ENG OIL CLR)	93-94		1	12337993
9.		8.917	NUT, HFH 5/16-18X.20 286M PC .67-OD (ENG OIL CLR PIPE BRKT)	93-94		1	1359887
10.		N.S.	COUPLING, ENG OIL CLR HOSE (PART OF 7)	93-94			
11.		8.962	HOSE (ENG OIL CLR OTLT) (PART OF 7)	93-94		AR	12388238
12.		8.948	CLAMP, WORM GEAR, 11/16" TO 1 5/16" (ENG OIL CLR OTLT HOSE) (AC-DELCO #12337891)	93-94		1	12337891

2002 GENERAL MOTORS SERVICE PARTS OPERATIONS-PONTIAC-25F