



## **DATA RESEARCH BY AUTOMOTIVE HOBBYISTS**

The enclosed research material was individually created and digitally printed for the specific customer who requested it and is intended for their exclusive, private and non-commercial use. This material is Copyright protected & is printed under license from the publisher and may not be transferred or redistributed in any way.

**Click [HERE](#) to Visit [ADOBE.COM](#)  
for Viewing & Printing Tips**

## **AIR CONDITIONING**

[Fig. 1: Compressor Circuit](#)

[Fig. 2: Manual A/C Circuit \(1 of 2\)](#)

[Fig. 3: Manual A/C Circuit \(2 of 2\)](#)

## **ANTI-LOCK BRAKES**

[Fig. 4: Anti-lock Brakes Circuit](#)

## **ANTI-THEFT**

[Fig. 5: Anti-theft Circuit](#)

## **BODY CONTROL MODULES**

[Fig. 6: Body Control Modules Circuit](#)

## **COMPUTER DATA LINES**

[Fig. 7: Computer Data Lines Circuit](#)

## **COOLING FAN**

[Fig. 8: Cooling Fan Circuit](#)

## **CRUISE CONTROL**

[Fig. 9: Cruise Control Circuit](#)

## **DEFOGGERS**

[Fig. 10: Defoggers Circuit](#)

## **ENGINE PERFORMANCE**

### **6.0L VIN U**

[Fig. 11: 6.0L VIN U, Engine Performance Circuit \(1 of 6\)](#)

[Fig. 12: 6.0L VIN U, Engine Performance Circuit \(2 of 6\)](#)

[Fig. 13: 6.0L VIN U, Engine Performance Circuit \(3 of 6\)](#)

[Fig. 14: 6.0L VIN U, Engine Performance Circuit \(4 of 6\)](#)

[Fig. 15: 6.0L VIN U, Engine Performance Circuit \(5 of 6\)](#)

[Fig. 16: 6.0L VIN U, Engine Performance Circuit \(6 of 6\)](#)

## **EXTERIOR LIGHTS**

[Fig. 17: Back-up Lamps Circuit](#)

[Fig. 18: Exterior Lamps Circuit \(1 of 2\)](#)

[Fig. 19: Exterior Lamps Circuit \(2 of 2\)](#)

## **GROUND DISTRIBUTION**

[Fig. 20: Ground Distribution Circuit \(1 of 3\)](#)

[Fig. 21: Ground Distribution Circuit \(2 of 3\)](#)

[Fig. 22: Ground Distribution Circuit \(3 of 3\)](#)

## **HEADLIGHTS**

[Fig. 23: Headlights Circuit \(1 of 2\)](#)

[Fig. 24: Headlights Circuit \(2 of 2\)](#)

## **HORN**

[Fig. 25: Horn Circuit](#)

## **INSTRUMENT CLUSTER**

[Fig. 26: Instrument Cluster Circuit](#)

## **INTERIOR LIGHTS**

[Fig. 27: Courtesy Lamps Circuit](#)

[Fig. 28: Instrument Illumination Circuit](#)

## **POWER DISTRIBUTION**

[Fig. 29: Power Distribution Circuit \(1 of 4\)](#)

[Fig. 30: Power Distribution Circuit \(2 of 4\)](#)

[Fig. 31: Power Distribution Circuit \(3 of 4\)](#)

[Fig. 32: Power Distribution Circuit \(4 of 4\)](#)

## **POWER MIRRORS**

[Fig. 33: Power Mirrors Circuit](#)

## **POWER SEATS**

[Fig. 34: Driver Power Seat Circuit](#)

[Fig. 35: Passenger Power Seat Circuit](#)

## **POWER WINDOWS**

[Fig. 36: Power Windows Circuit](#)

## **RADIO**

[Fig. 37: Radio Circuit](#)

## **SHIFT INTERLOCK**

[Fig. 38: Shift Interlock Circuit](#)

## **STARTING/CHARGING**

[Fig. 39: Charging Circuit](#)

[Fig. 40: Starting Circuit](#)

## **SUPPLEMENTAL RESTRAINTS**

[Fig. 41: Supplemental Restraints Circuit](#)

## **TRANSMISSION**

[Fig. 42: A/T Circuit \(1 of 2\)](#)

[Fig. 43: A/T Circuit \(2 of 2\)](#)

[Fig. 44: M/T Circuit](#)

## **TRUNK, TAILGATE, FUEL DOOR**

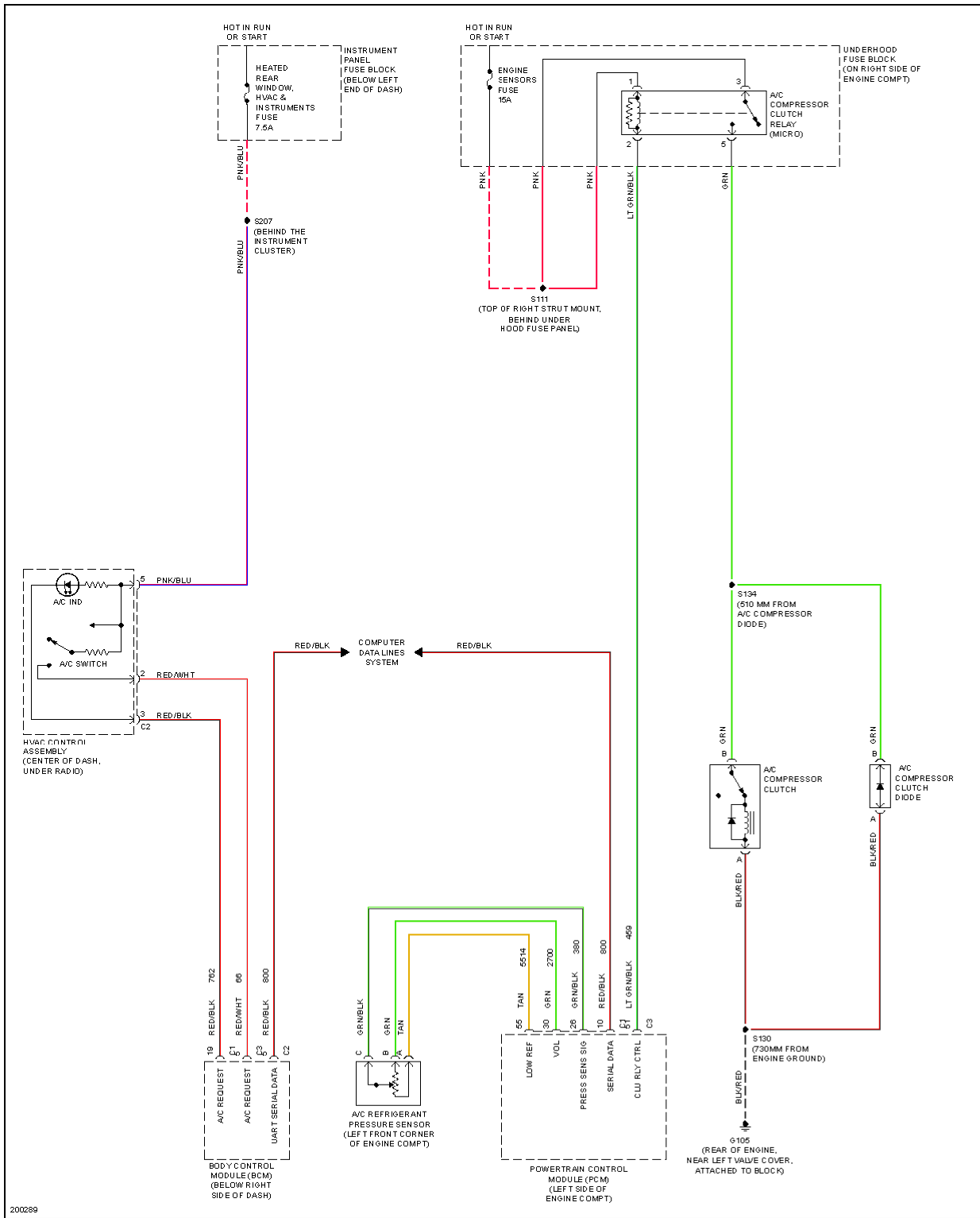
[Fig. 45: Trunk, Tailgate, Fuel Door Circuit](#)

## **WARNING SYSTEMS**

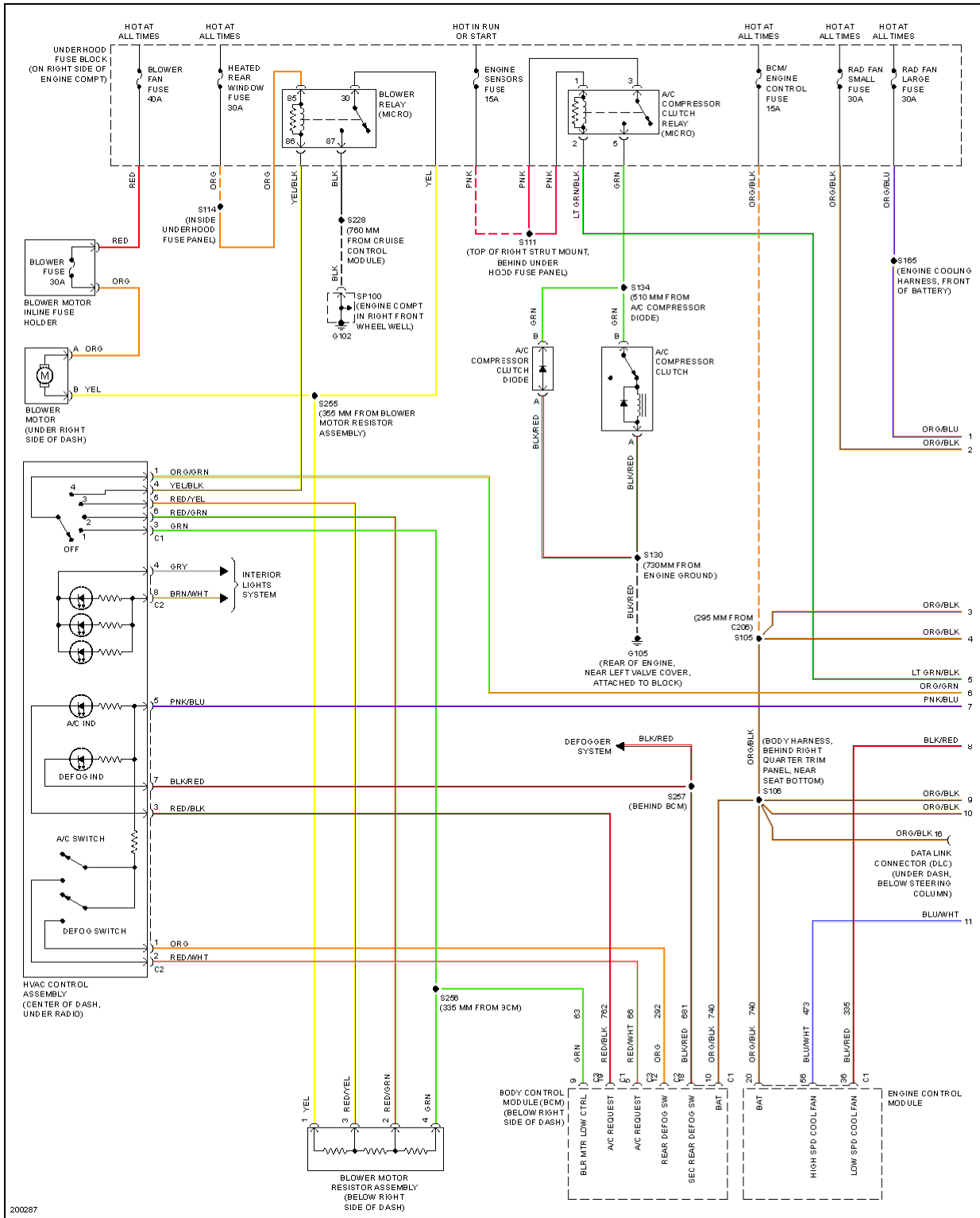
[Fig. 46: Warning Systems Circuit](#)

## **WIPER/WASHER**

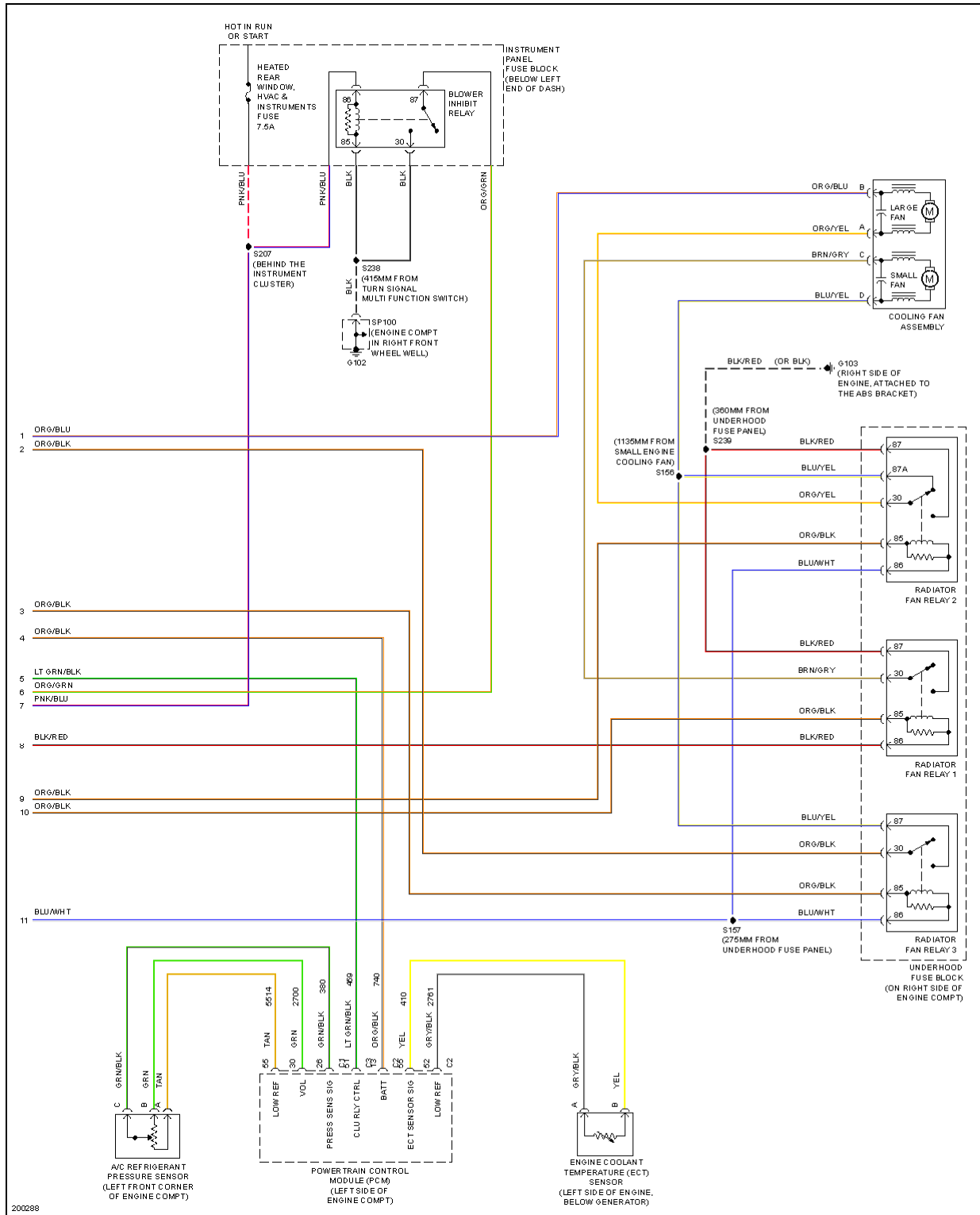
[Fig. 47: Wiper/Washer Circuit](#)



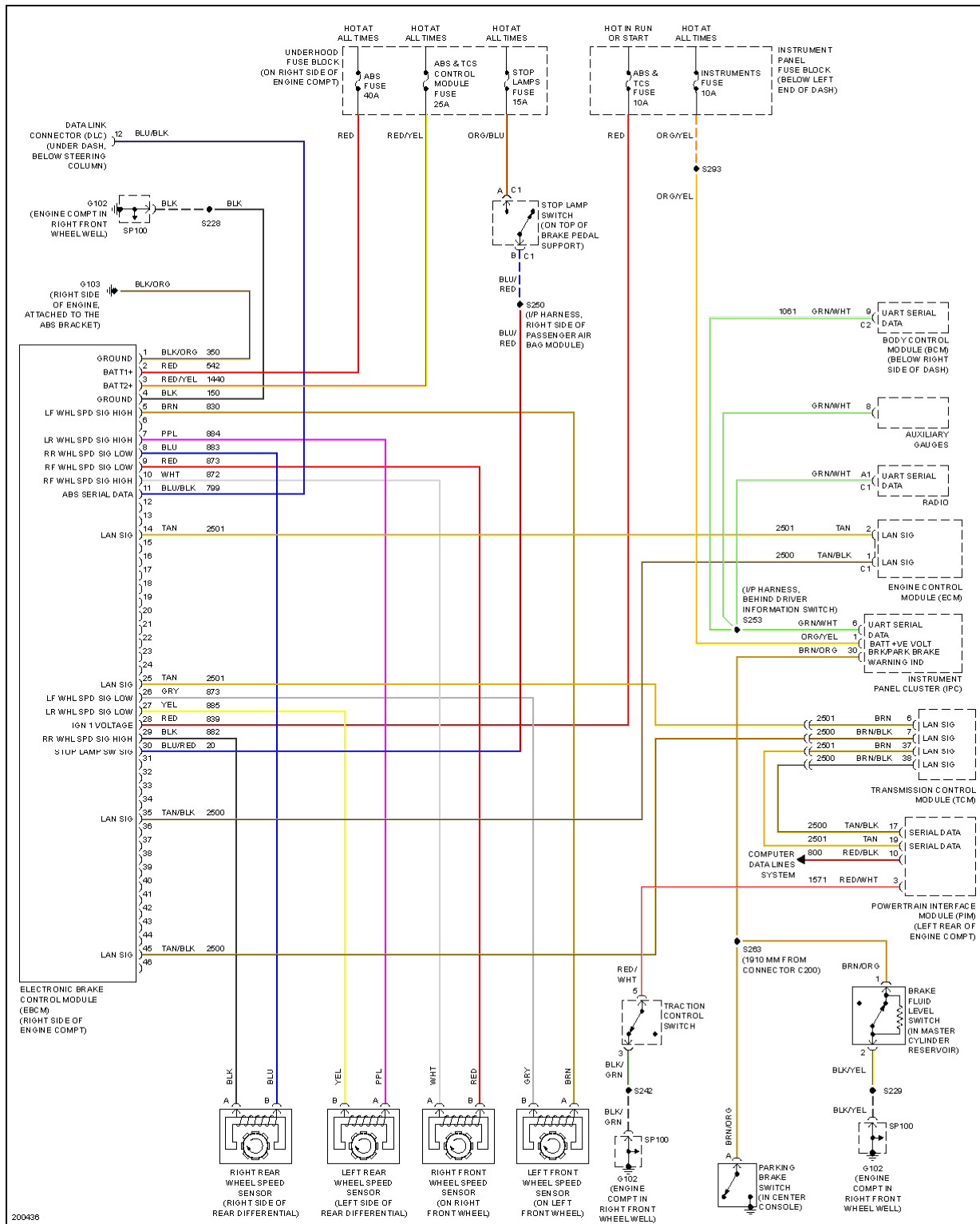
**Fig. 1: Compressor Circuit**



**Fig. 2: Manual A/C Circuit (1 of 2)**

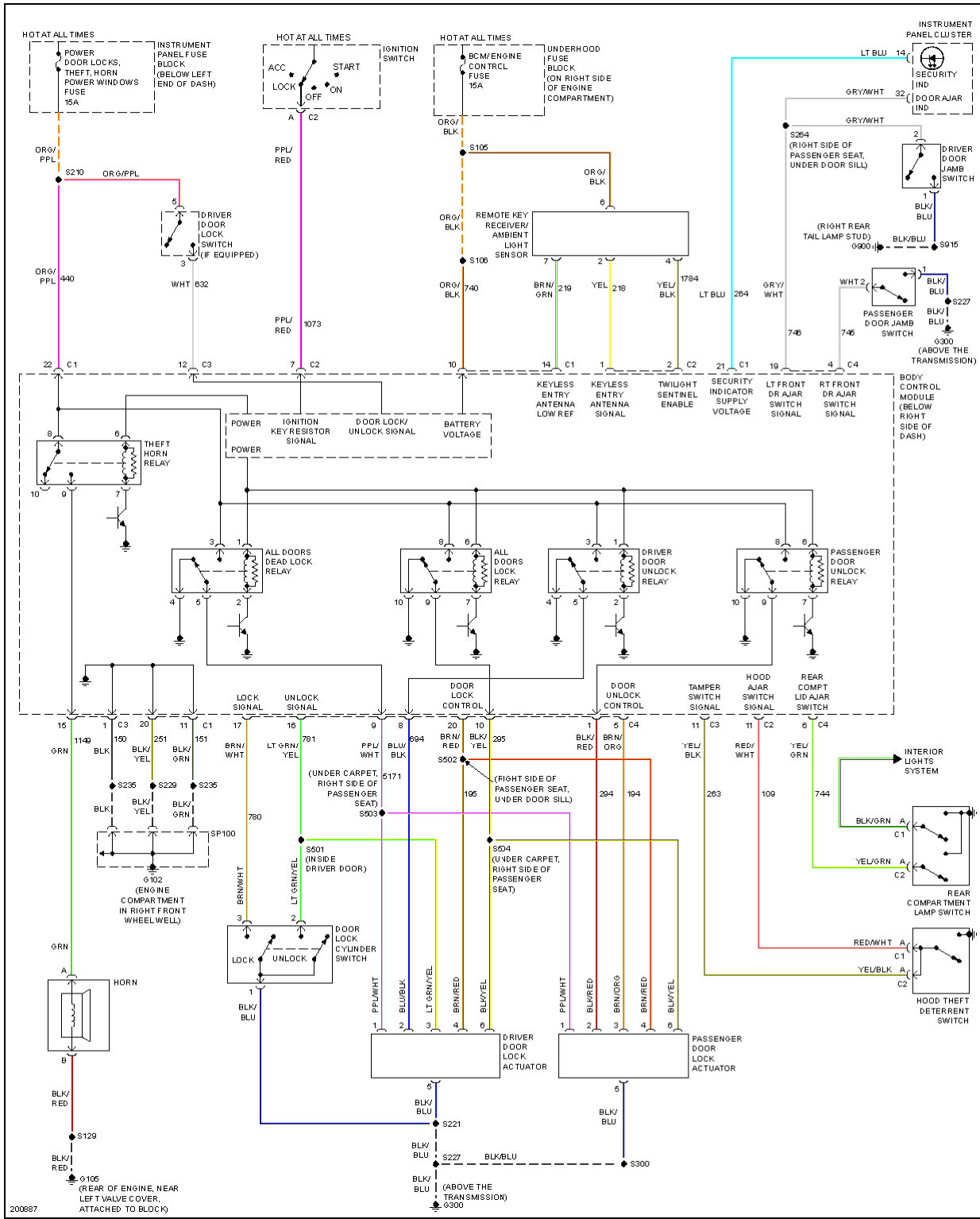


**Fig. 3: Manual A/C Circuit (2 of 2)**

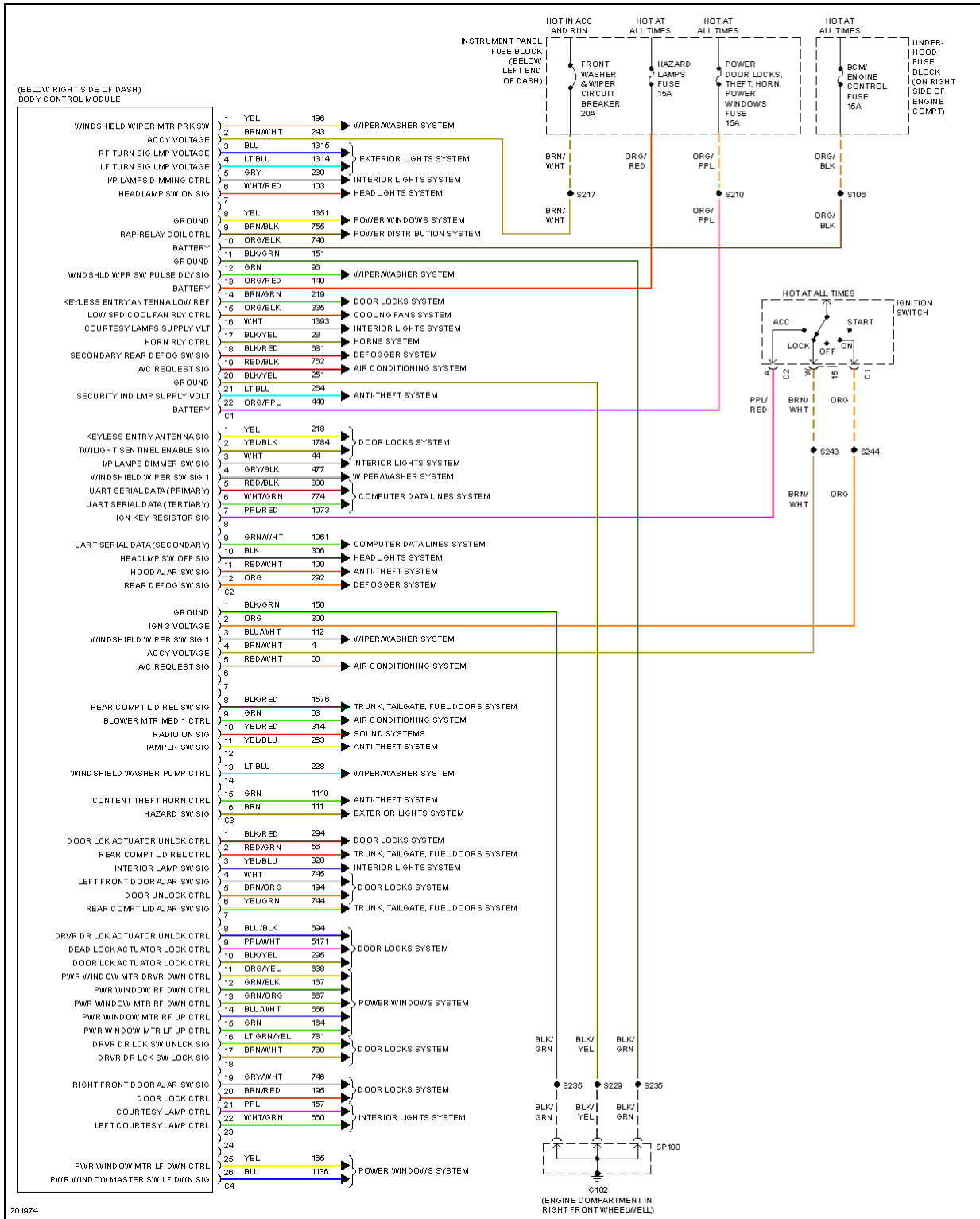


**Fig. 4: Anti-lock Brakes Circuit**

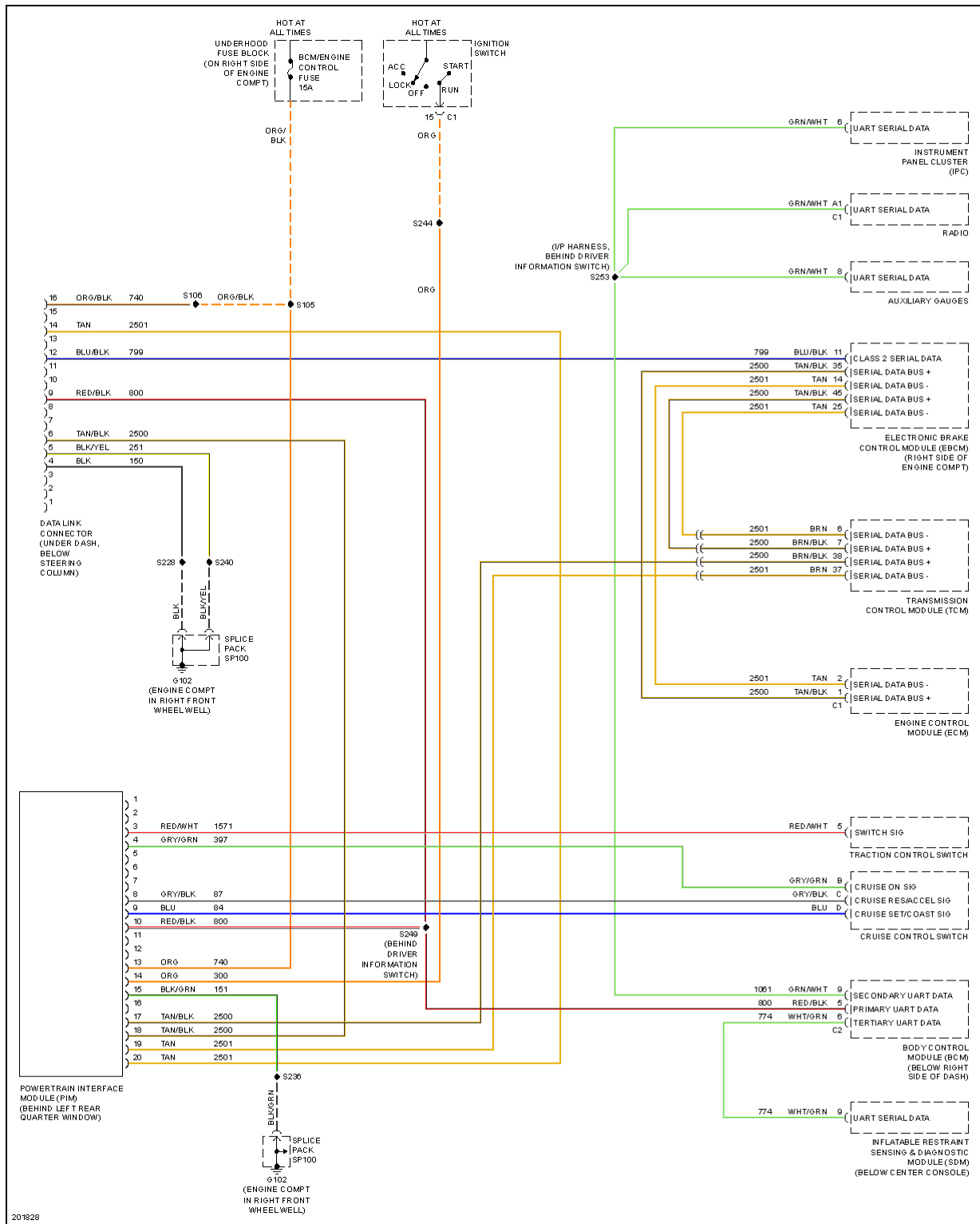




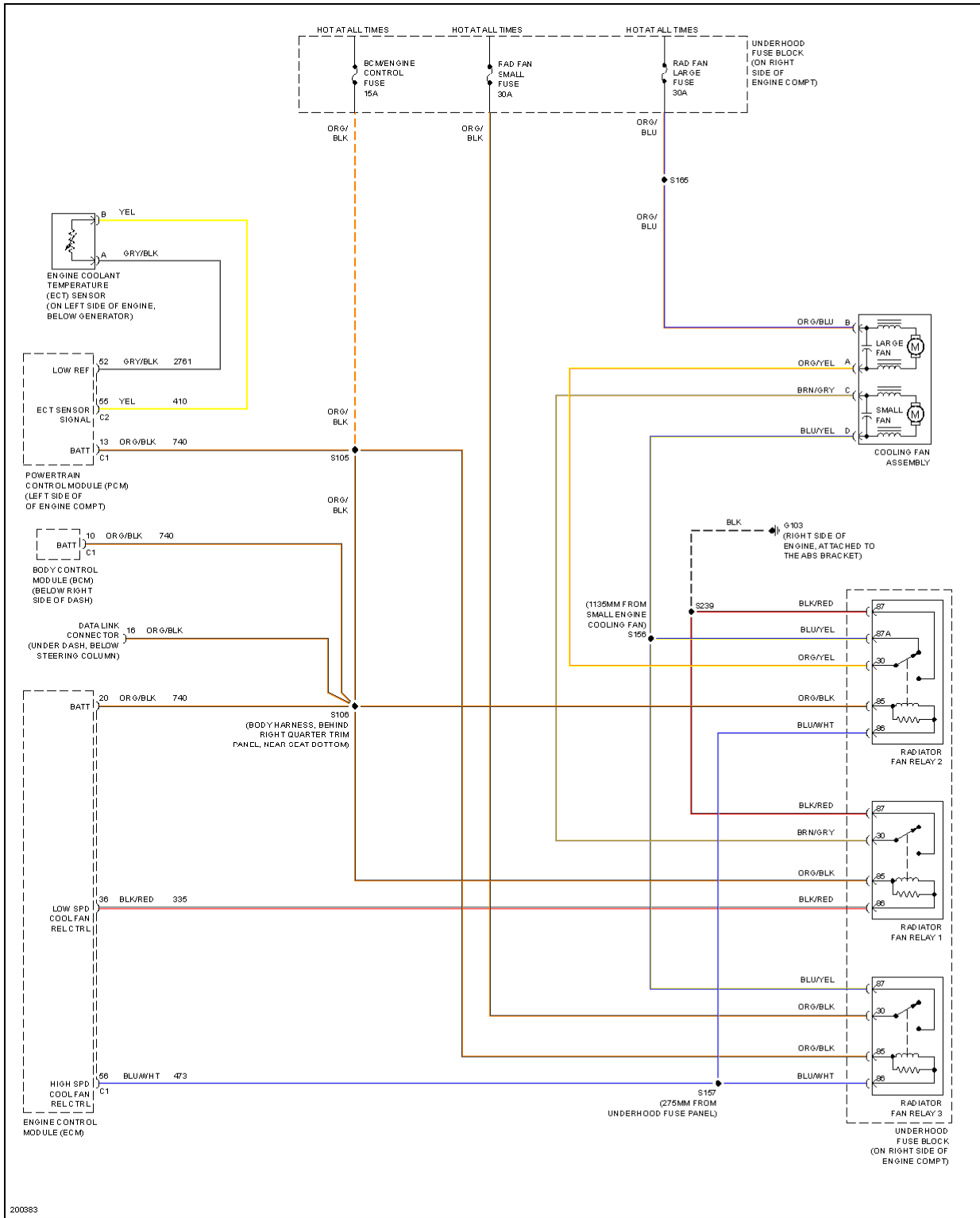
**Fig. 5: Anti-theft Circuit**



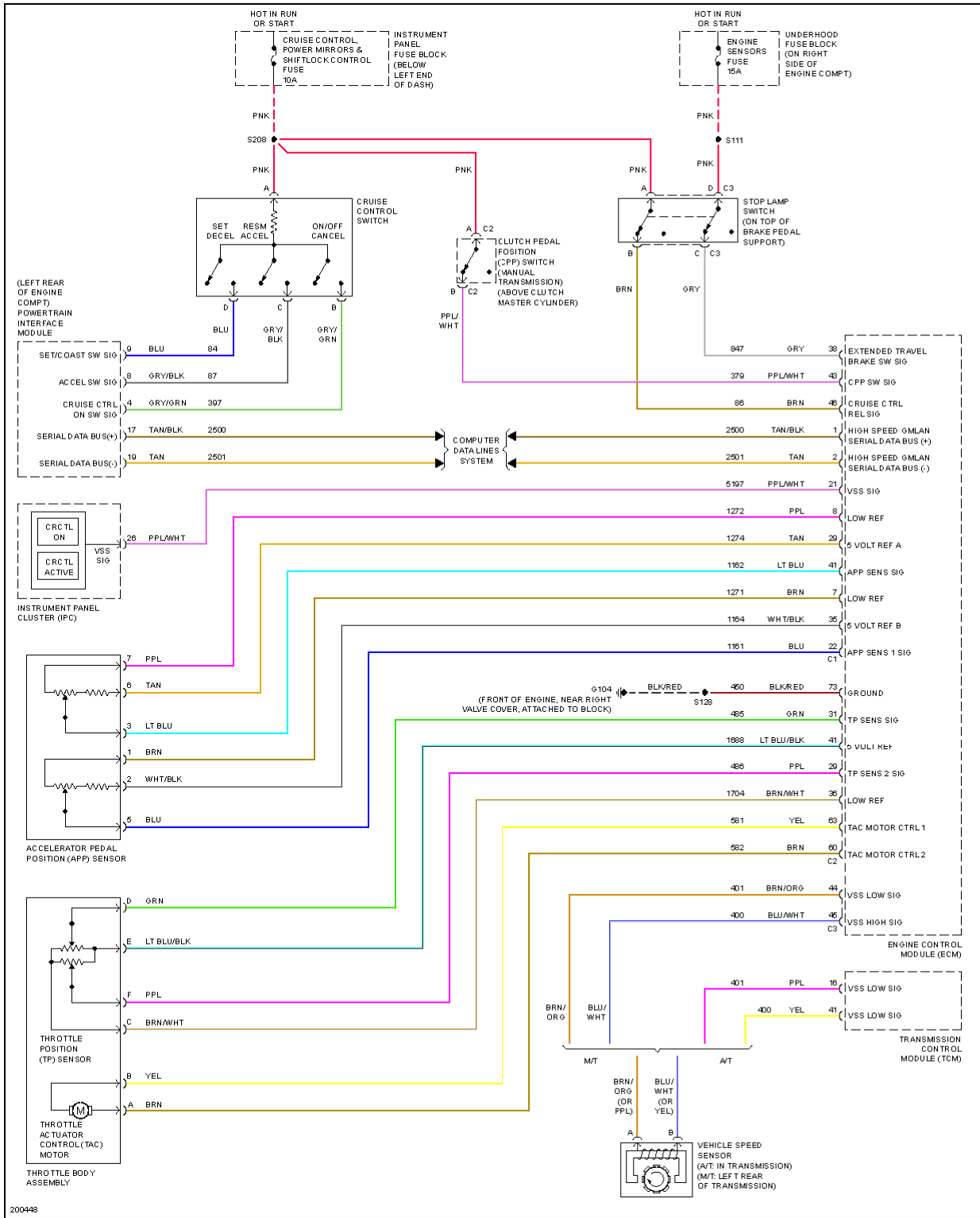
**Fig. 6: Body Control Modules Circuit**



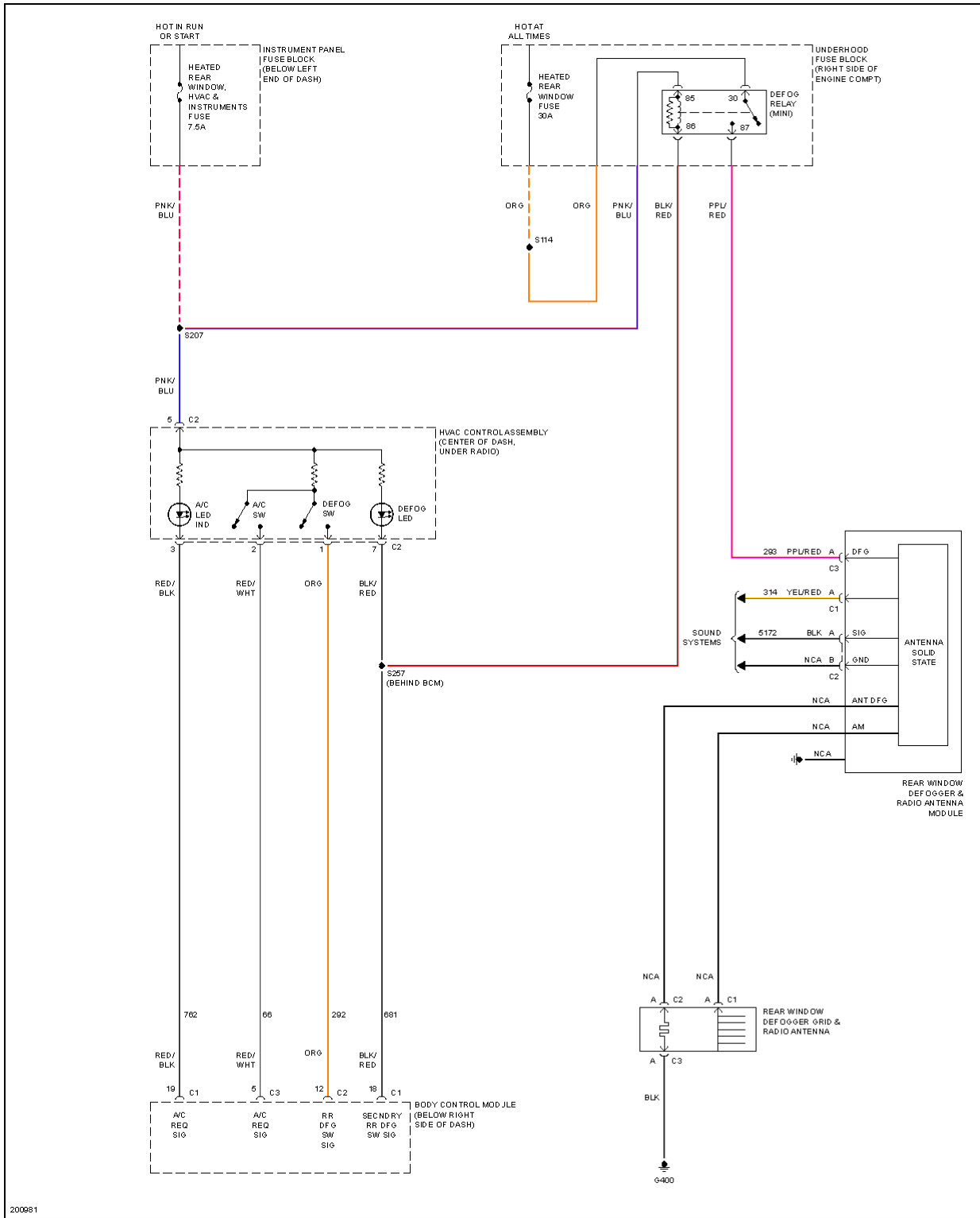
**Fig. 7: Computer Data Lines Circuit**



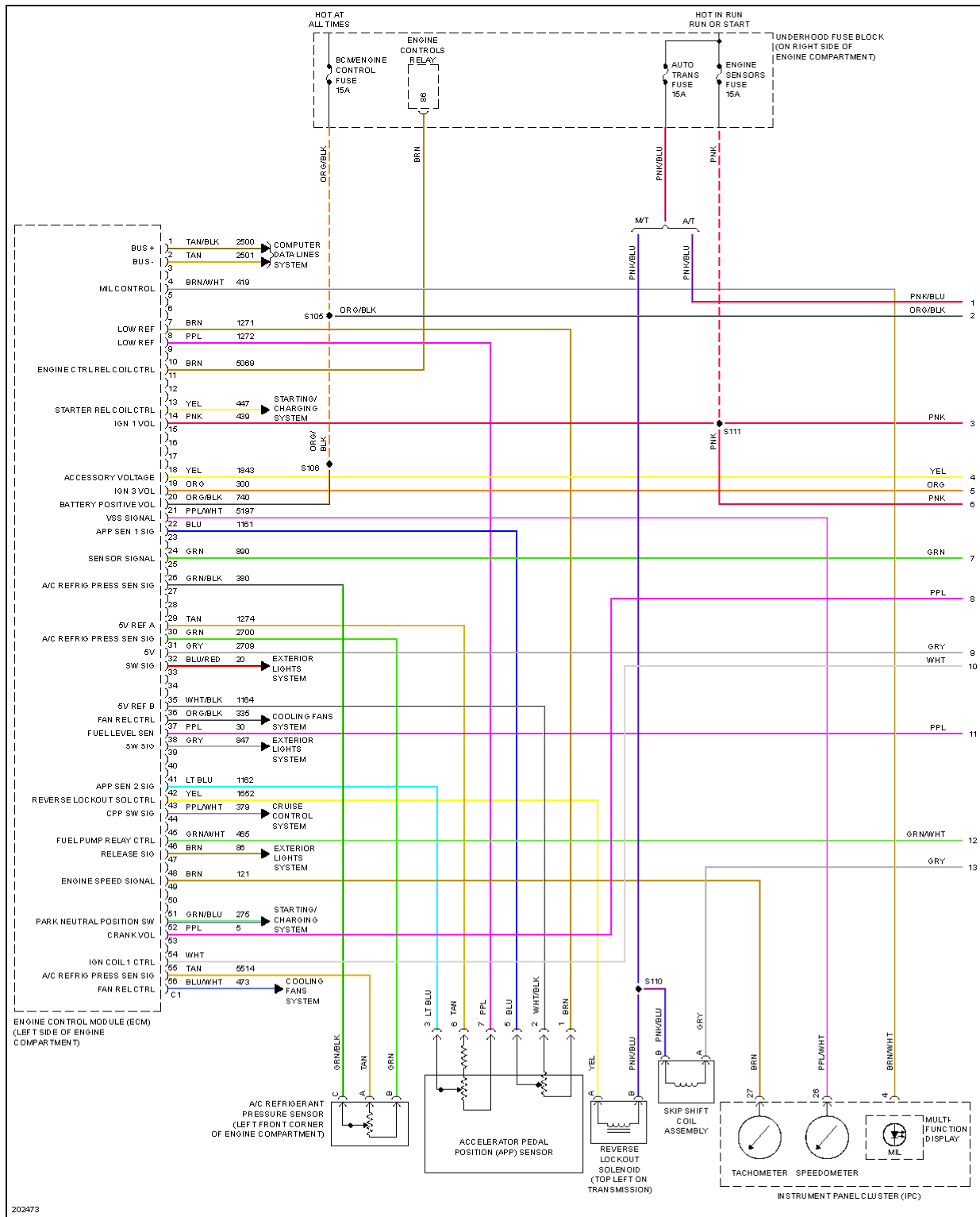
**Fig. 8: Cooling Fan Circuit**



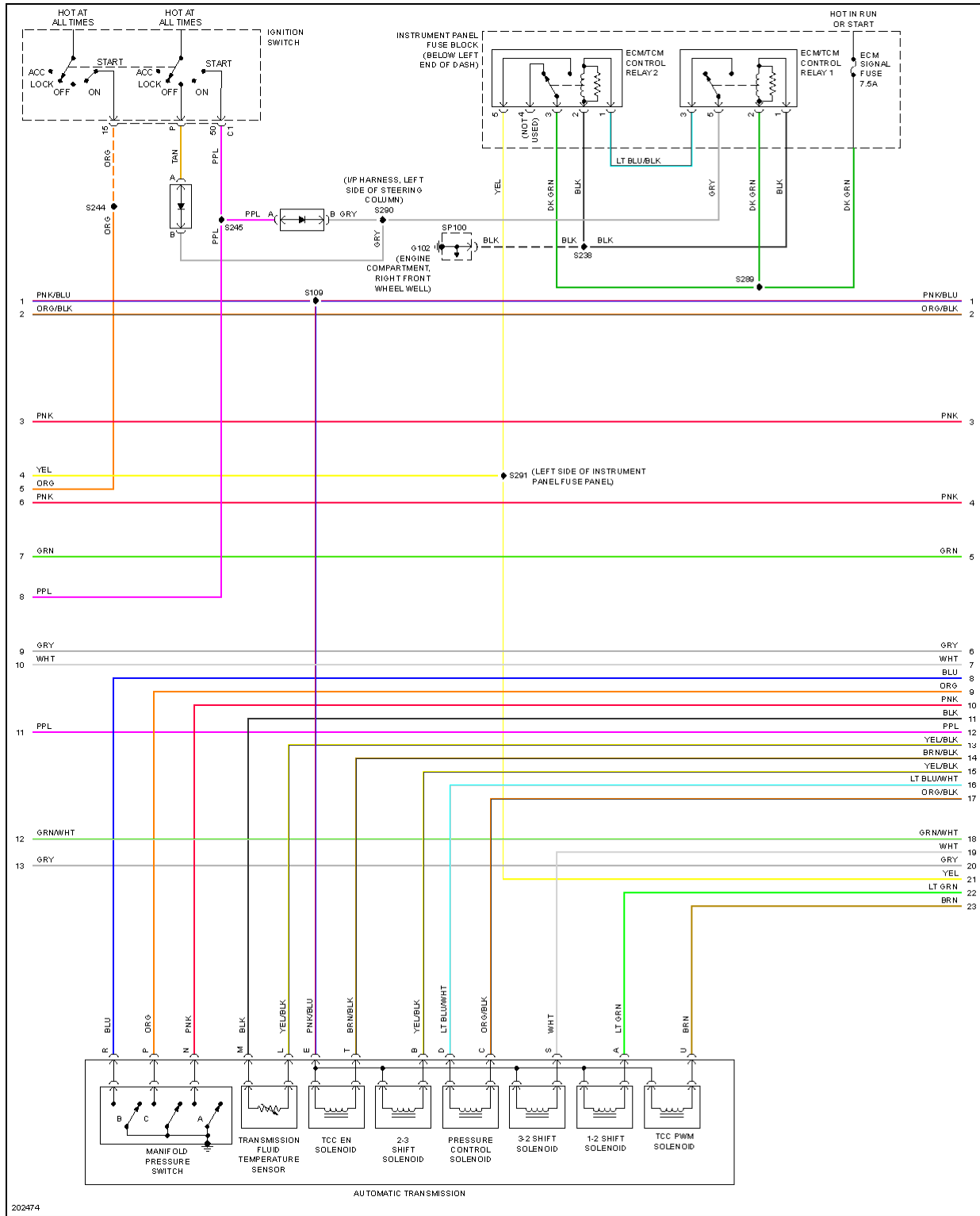
**Fig. 9: Cruise Control Circuit**



**Fig. 10: Defoggers Circuit**

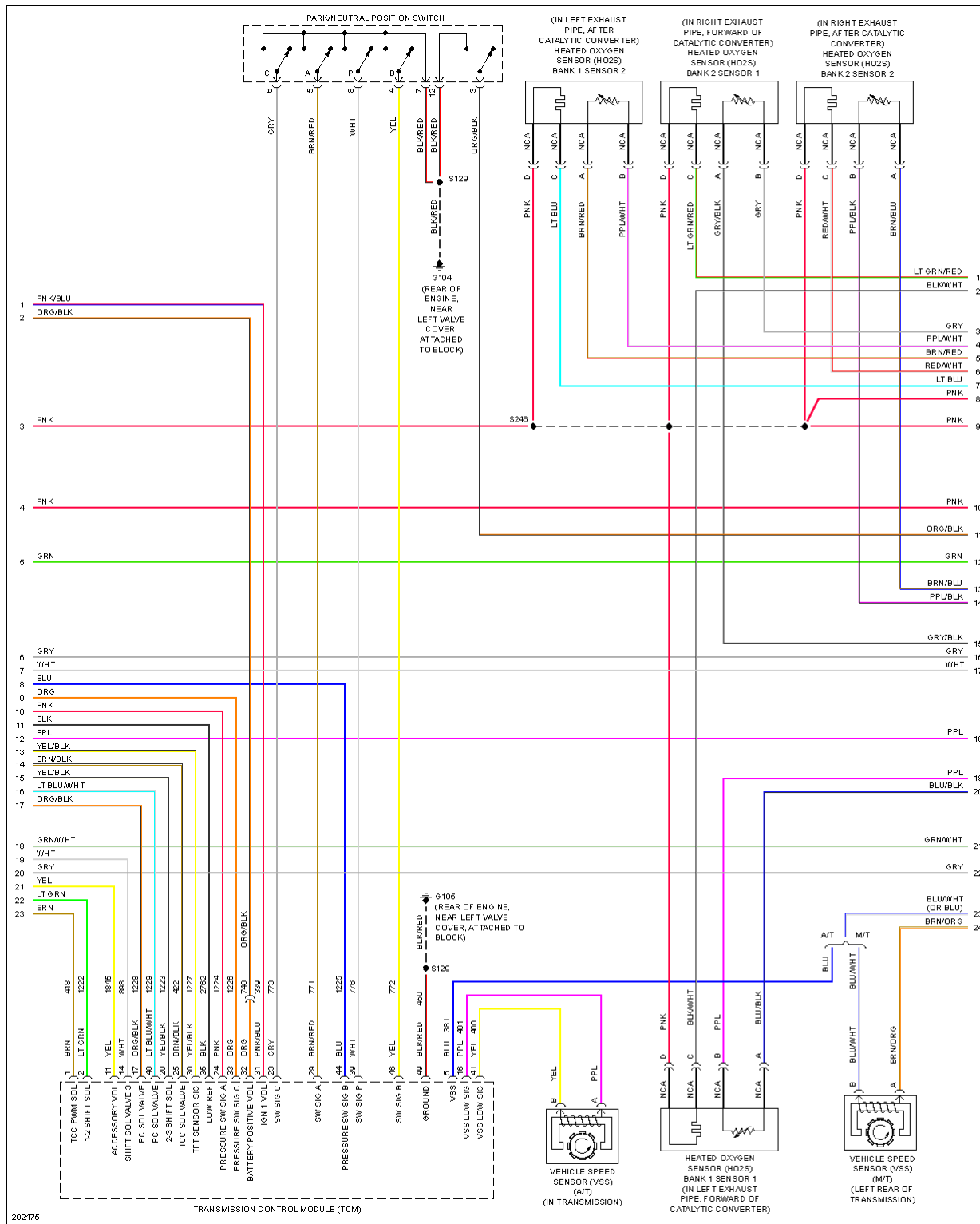


**Fig. 11: 6.0L VIN U, Engine Performance Circuit (1 of 6)**

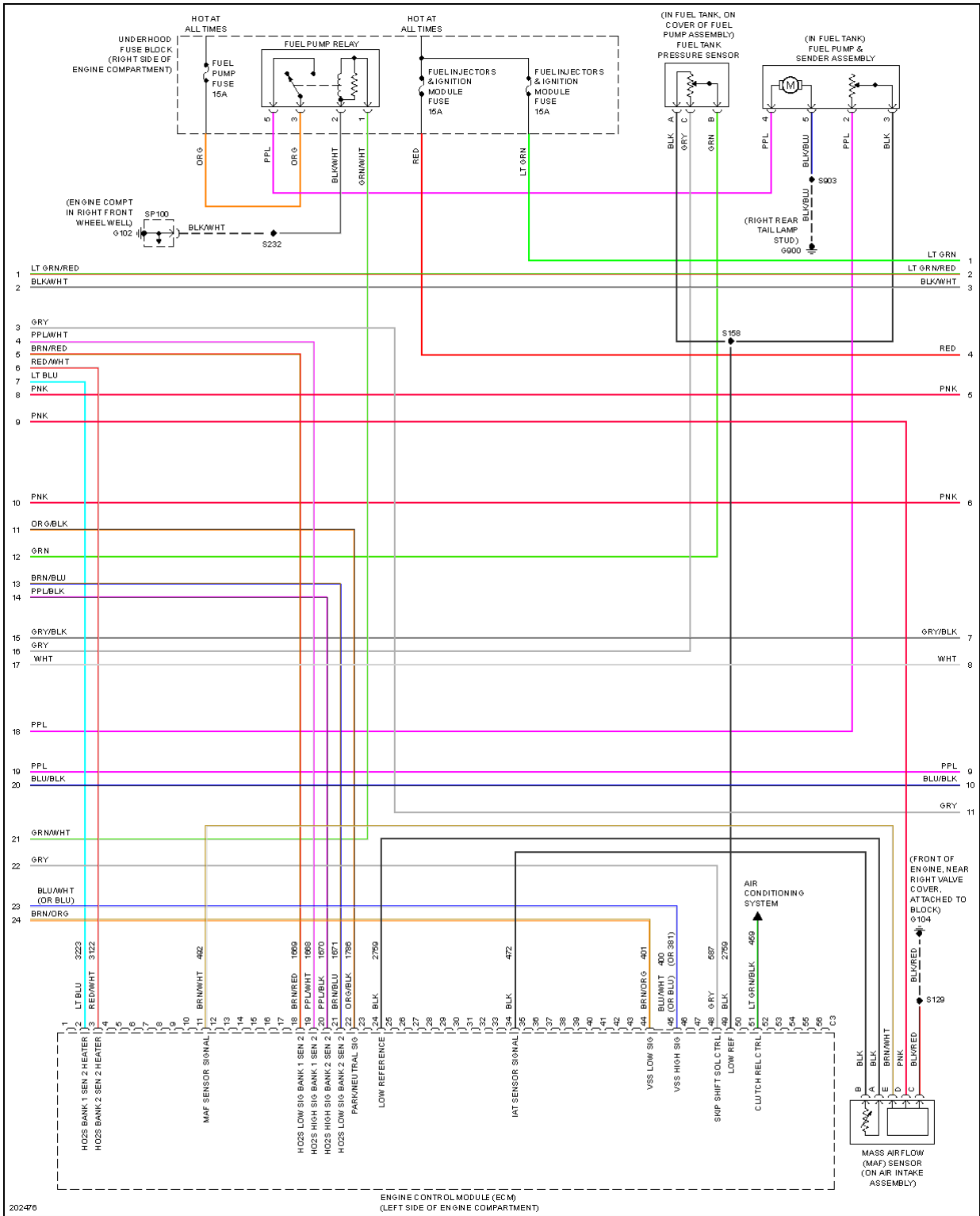


**Fig. 12: 6.0L VIN U, Engine Performance Circuit (2 of 6)**

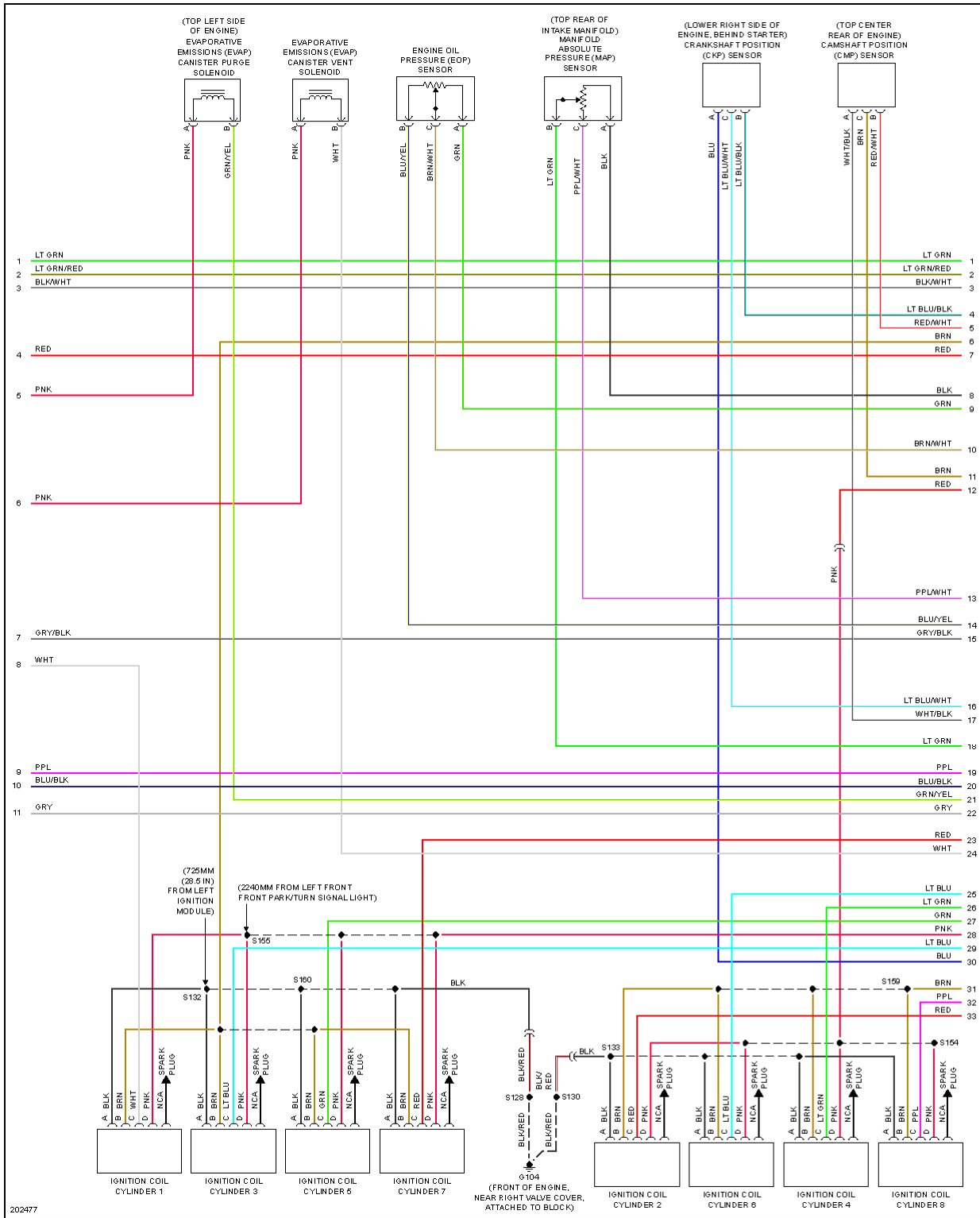




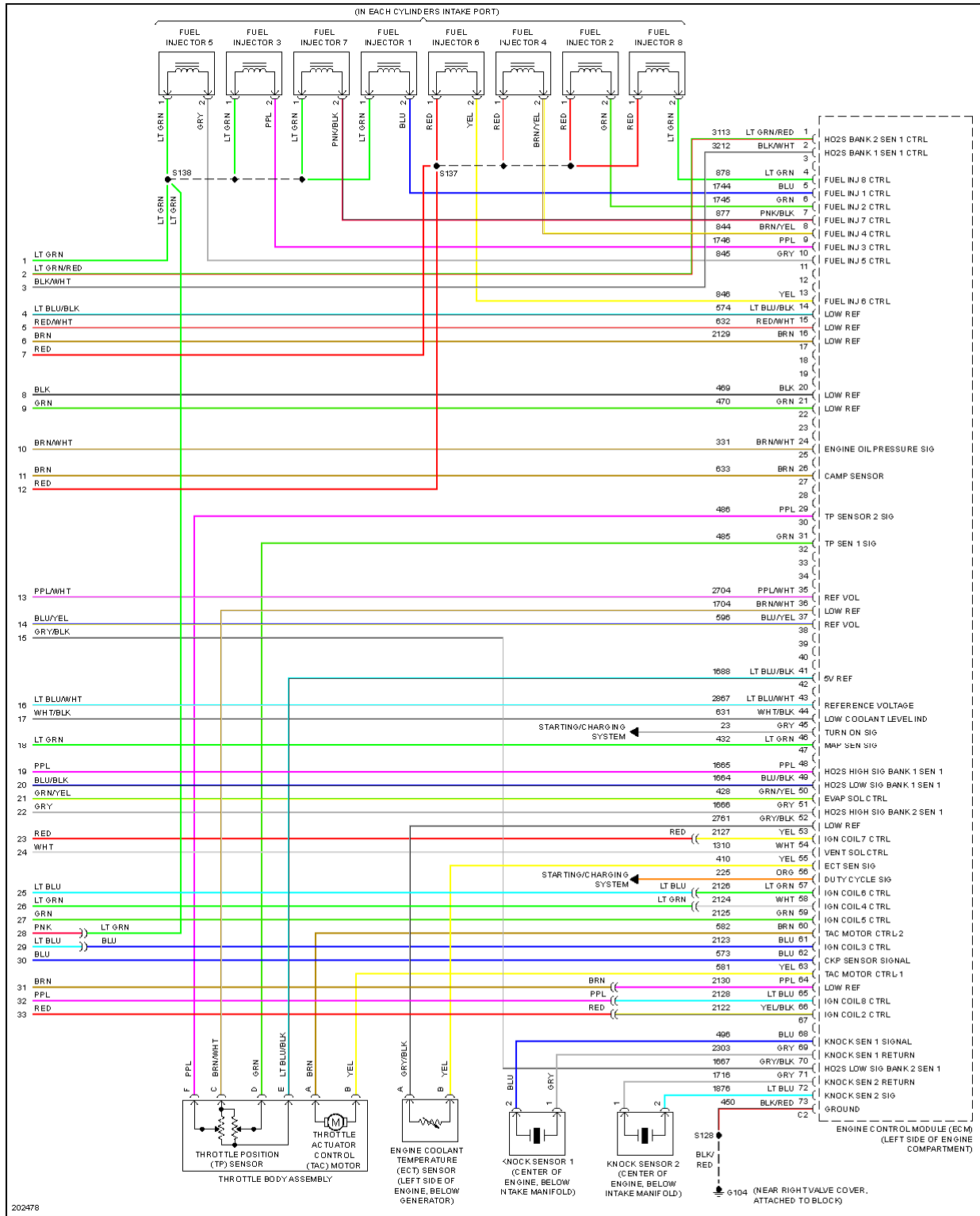
**Fig. 13: 6.0L VIN U, Engine Performance Circuit (3 of 6)**



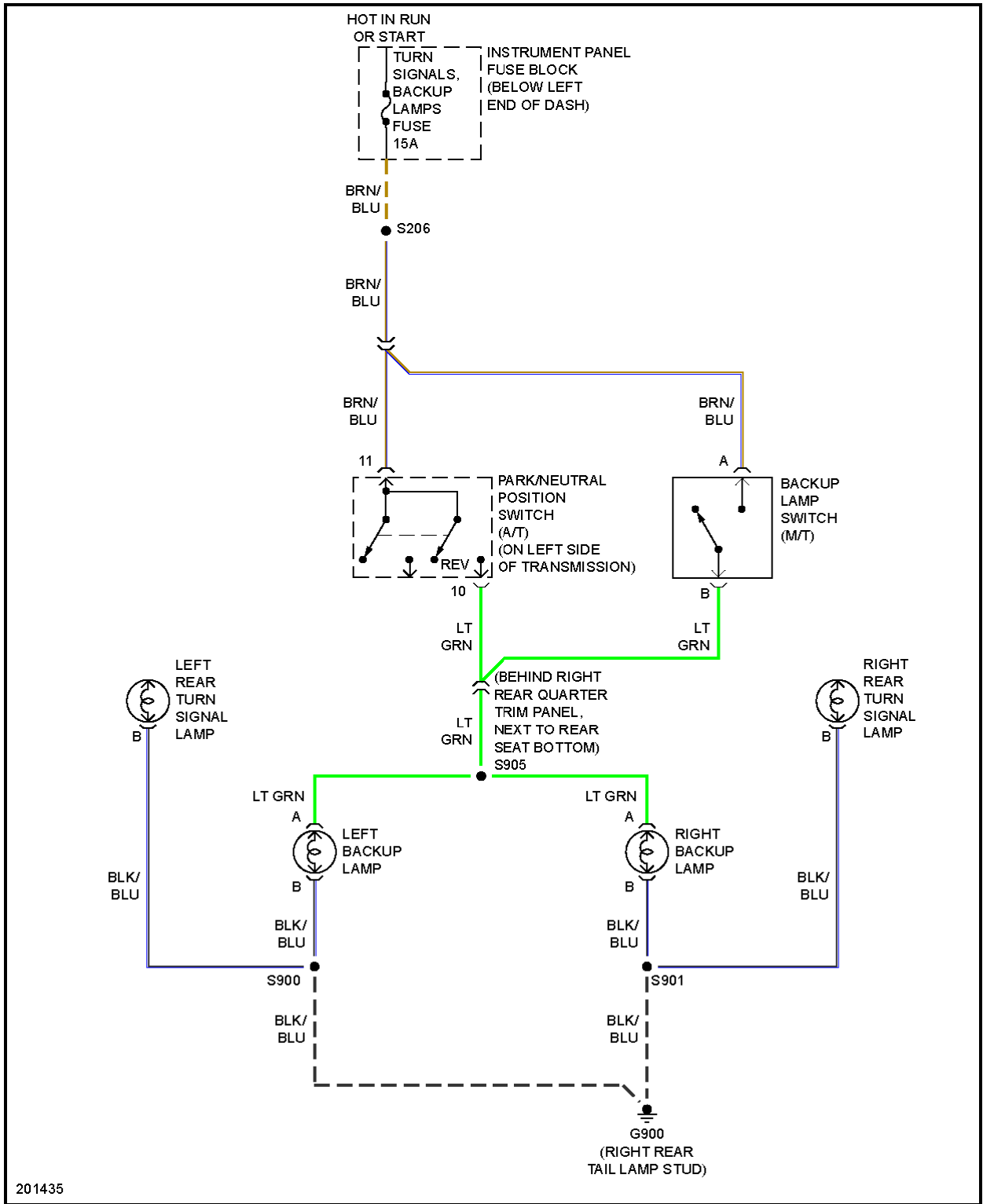
**Fig. 14: 6.0L VIN U, Engine Performance Circuit (4 of 6)**



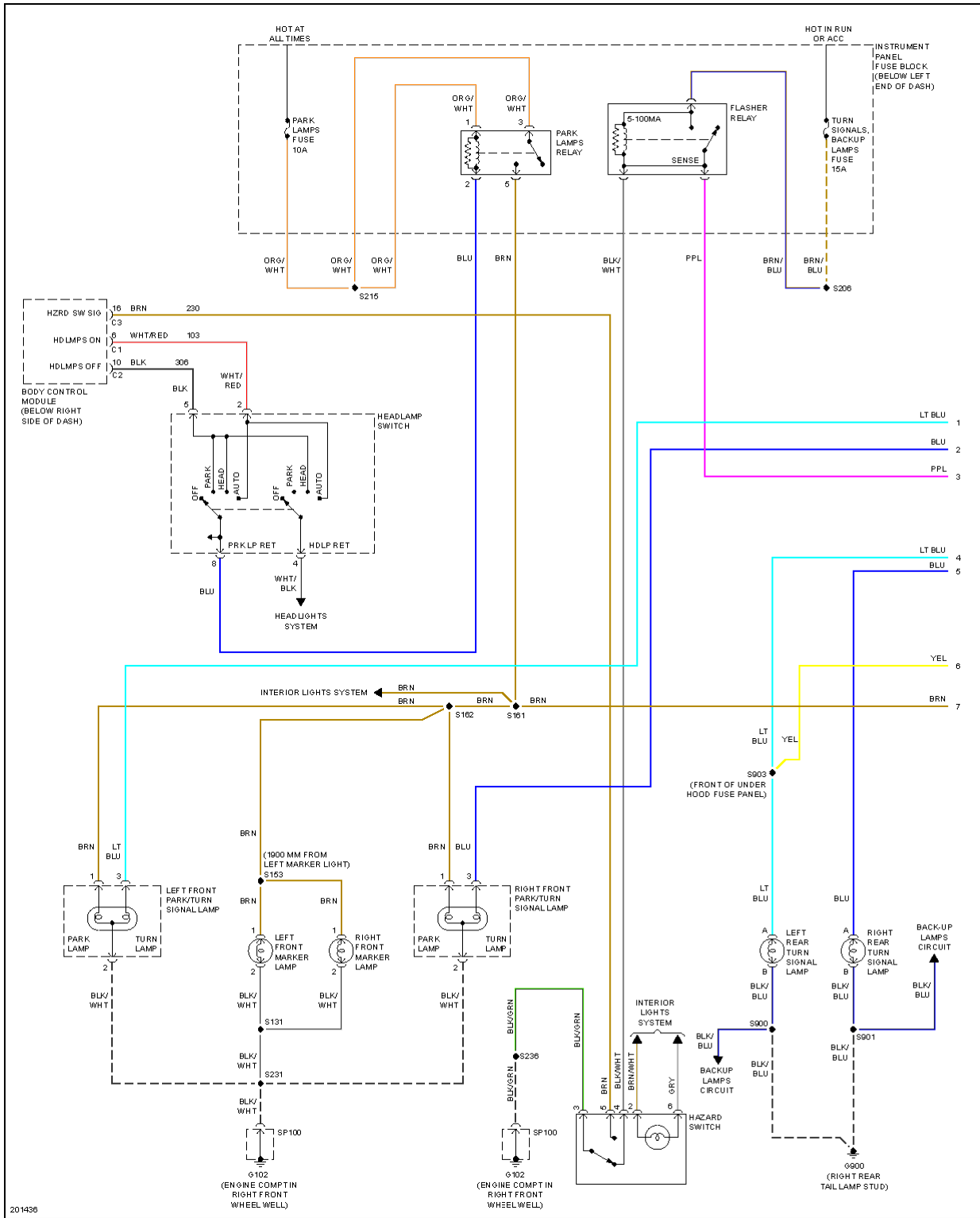
**Fig. 15: 6.0L VIN U, Engine Performance Circuit (5 of 6)**



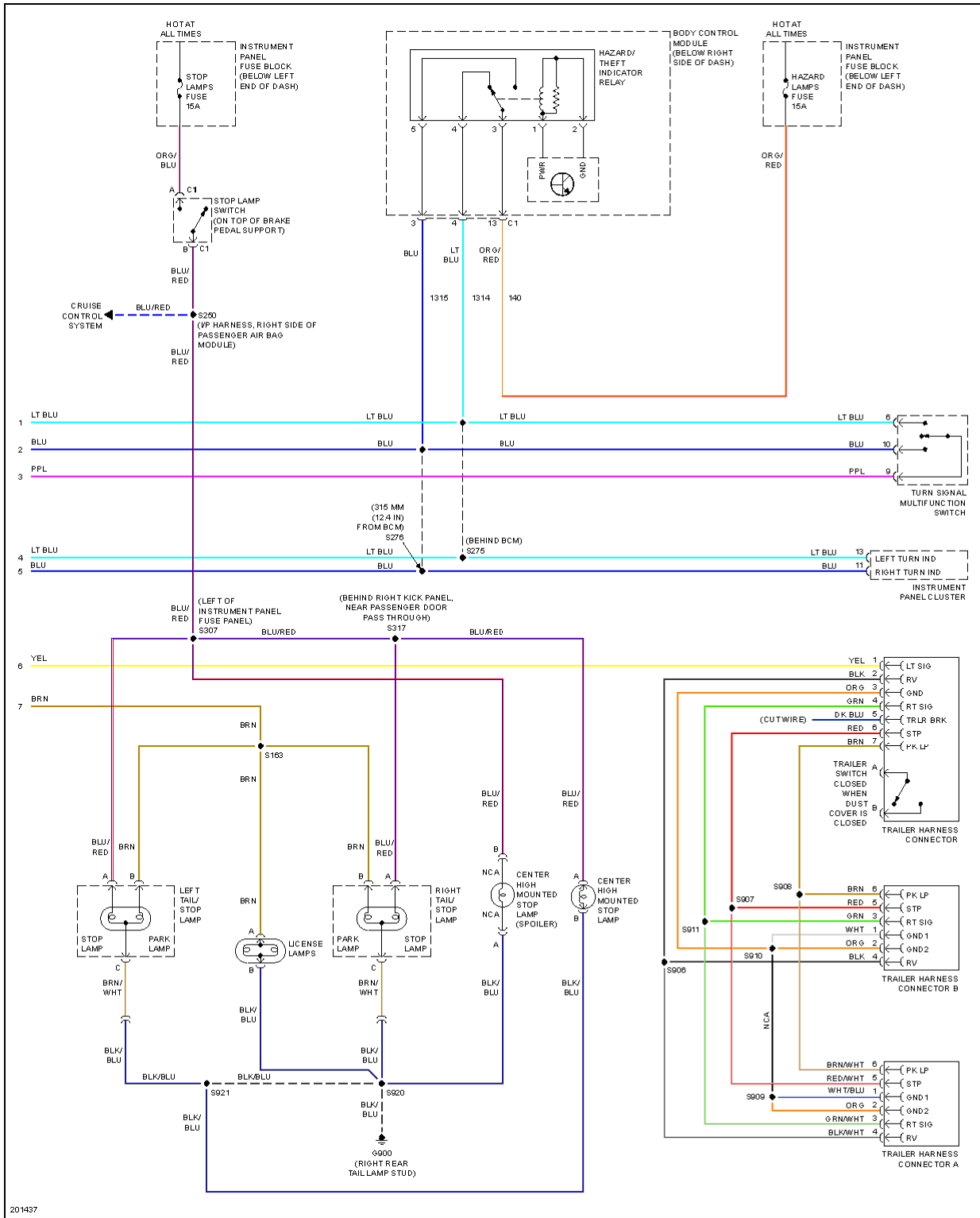
**Fig. 16: 6.0L VIN U, Engine Performance Circuit (6 of 6)**



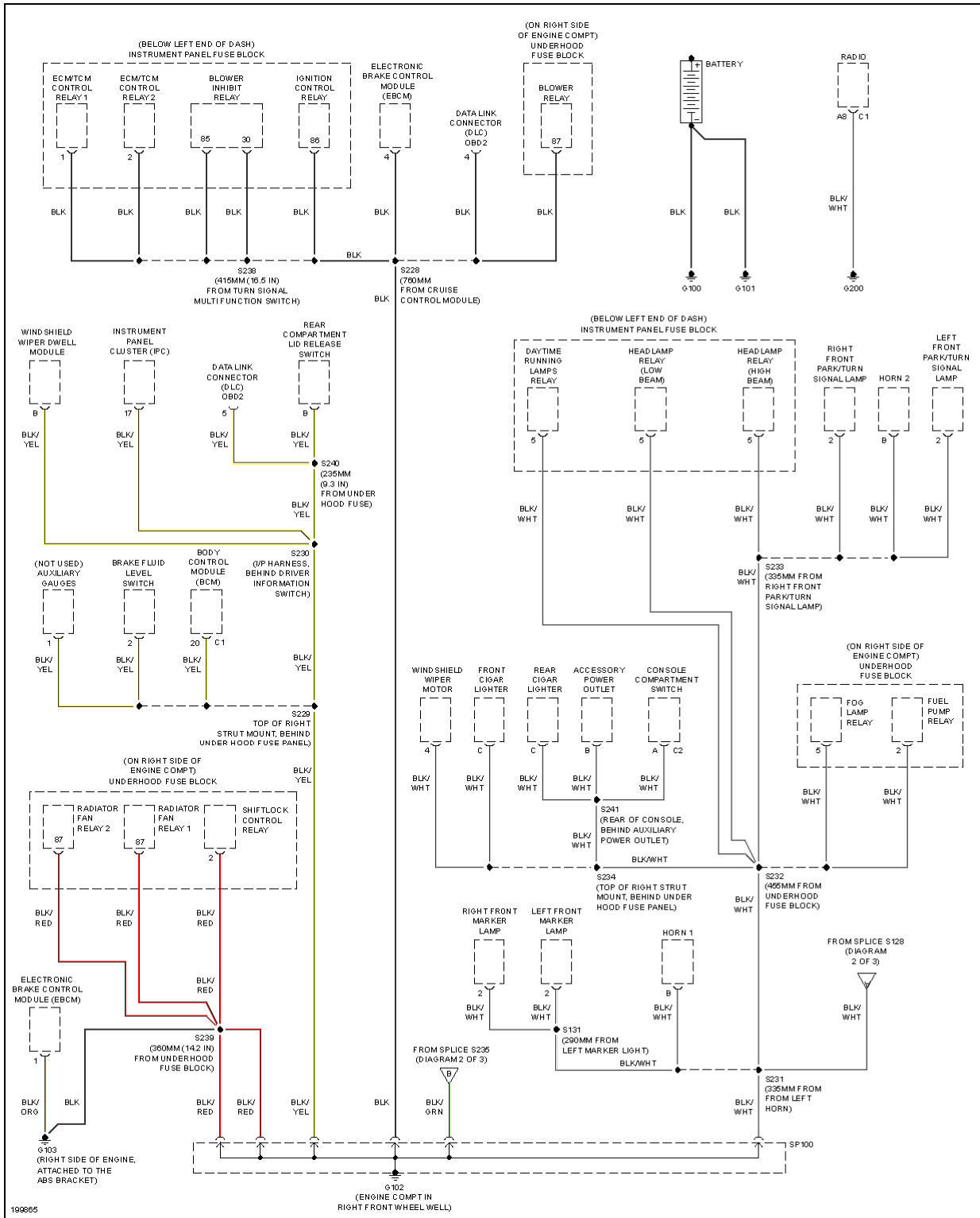
**Fig. 17: Back-up Lamps Circuit**



**Fig. 18: Exterior Lamps Circuit (1 of 2)**



**Fig. 19: Exterior Lamps Circuit (2 of 2)**



**Fig. 20: Ground Distribution Circuit (1 of 3)**



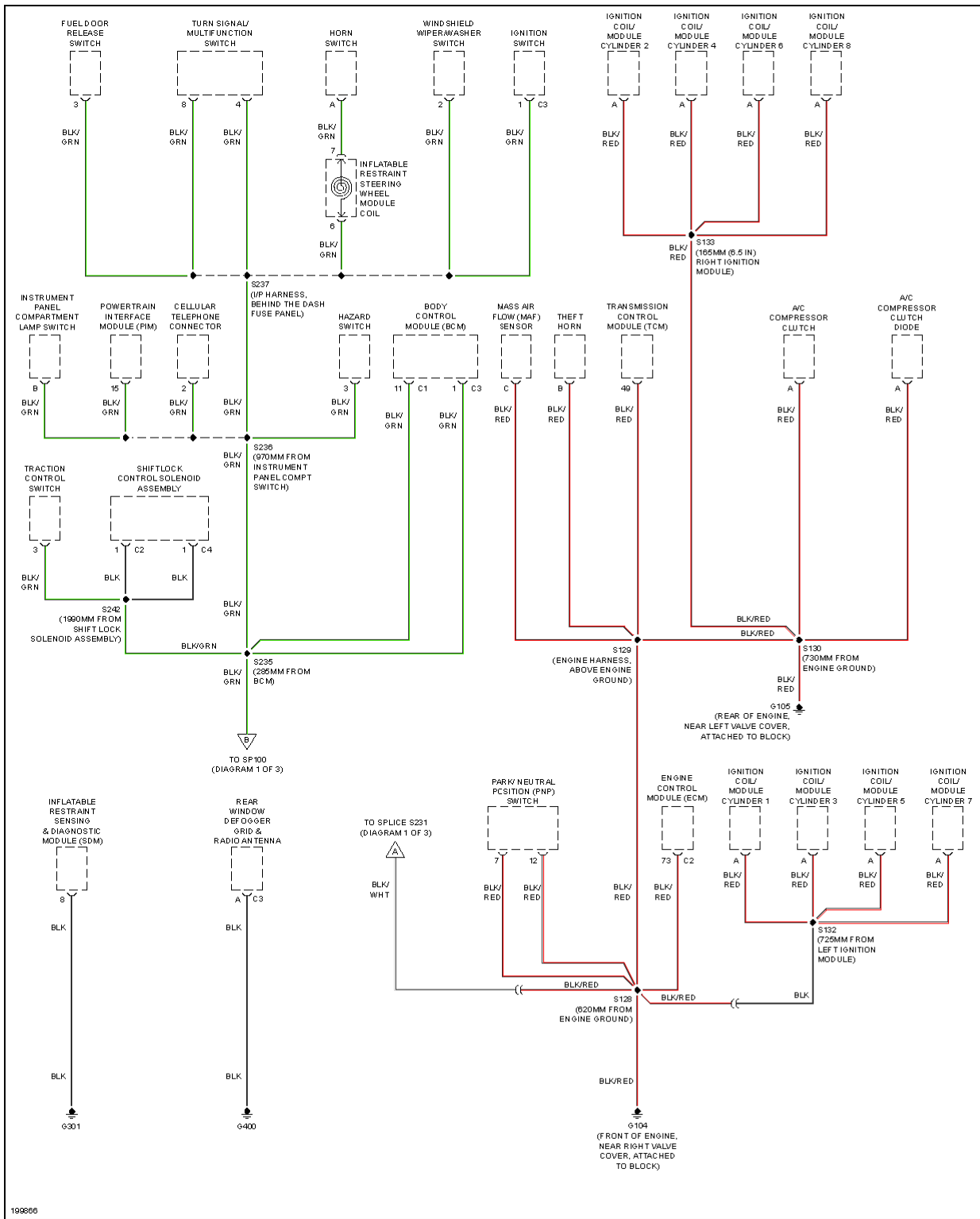
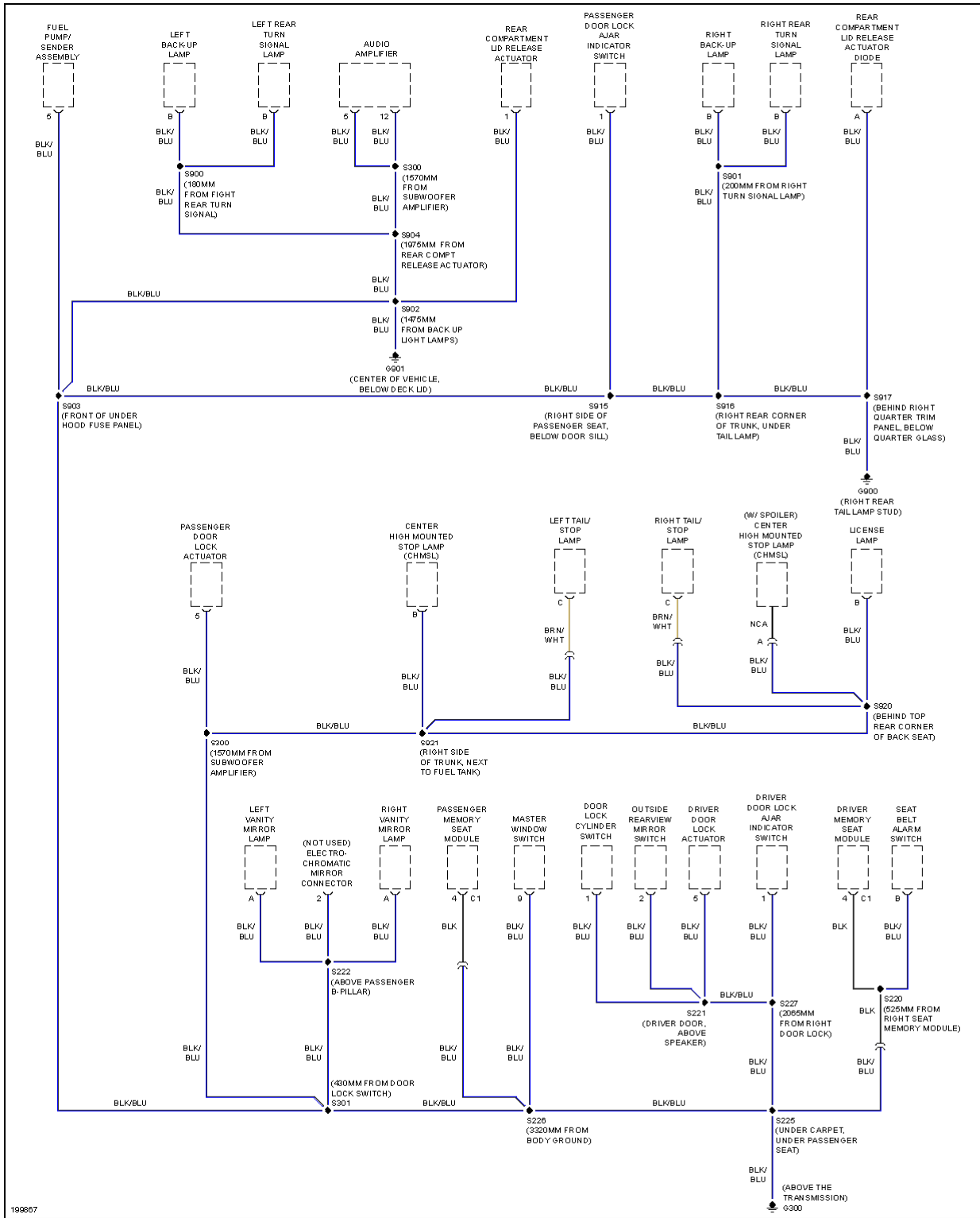
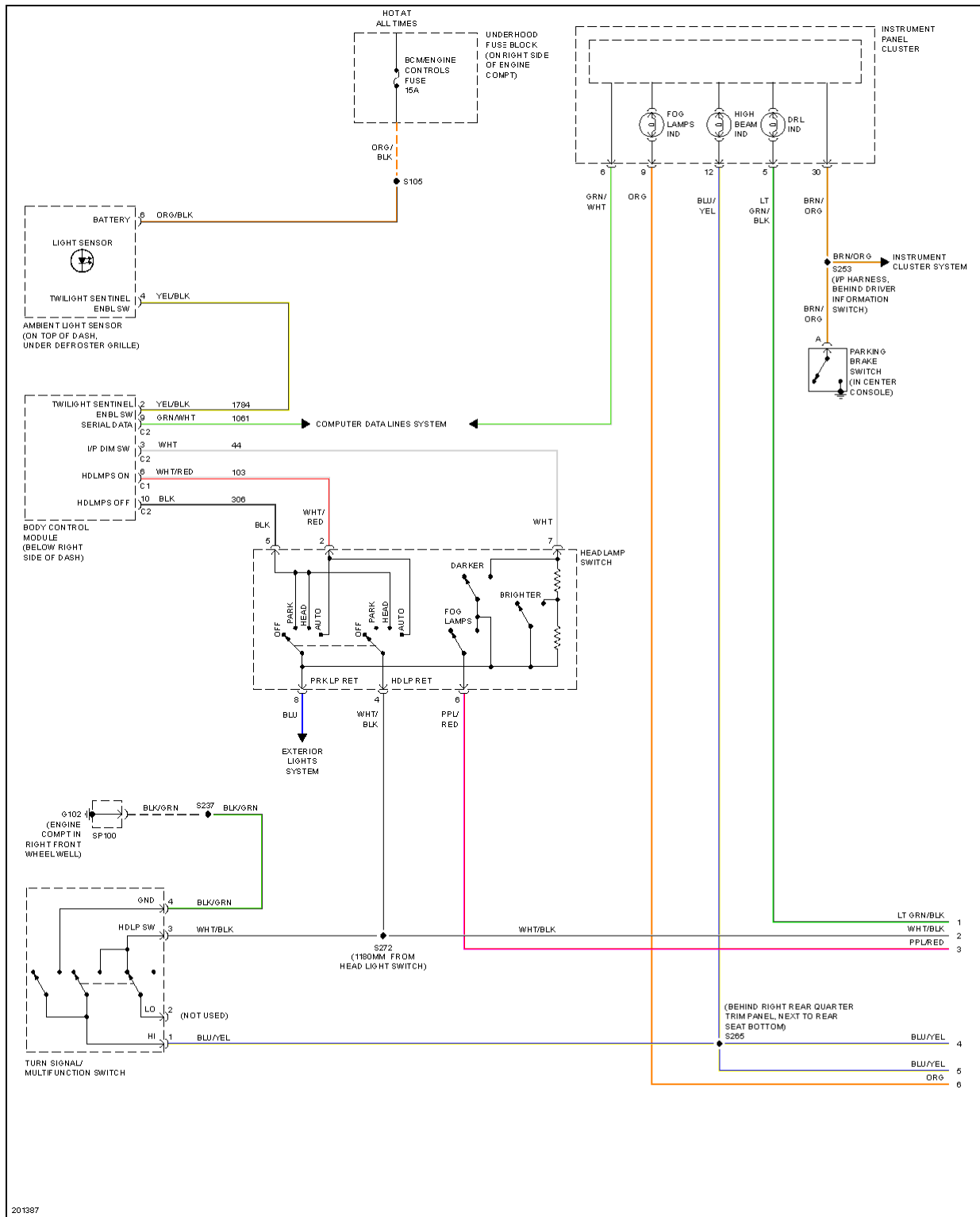


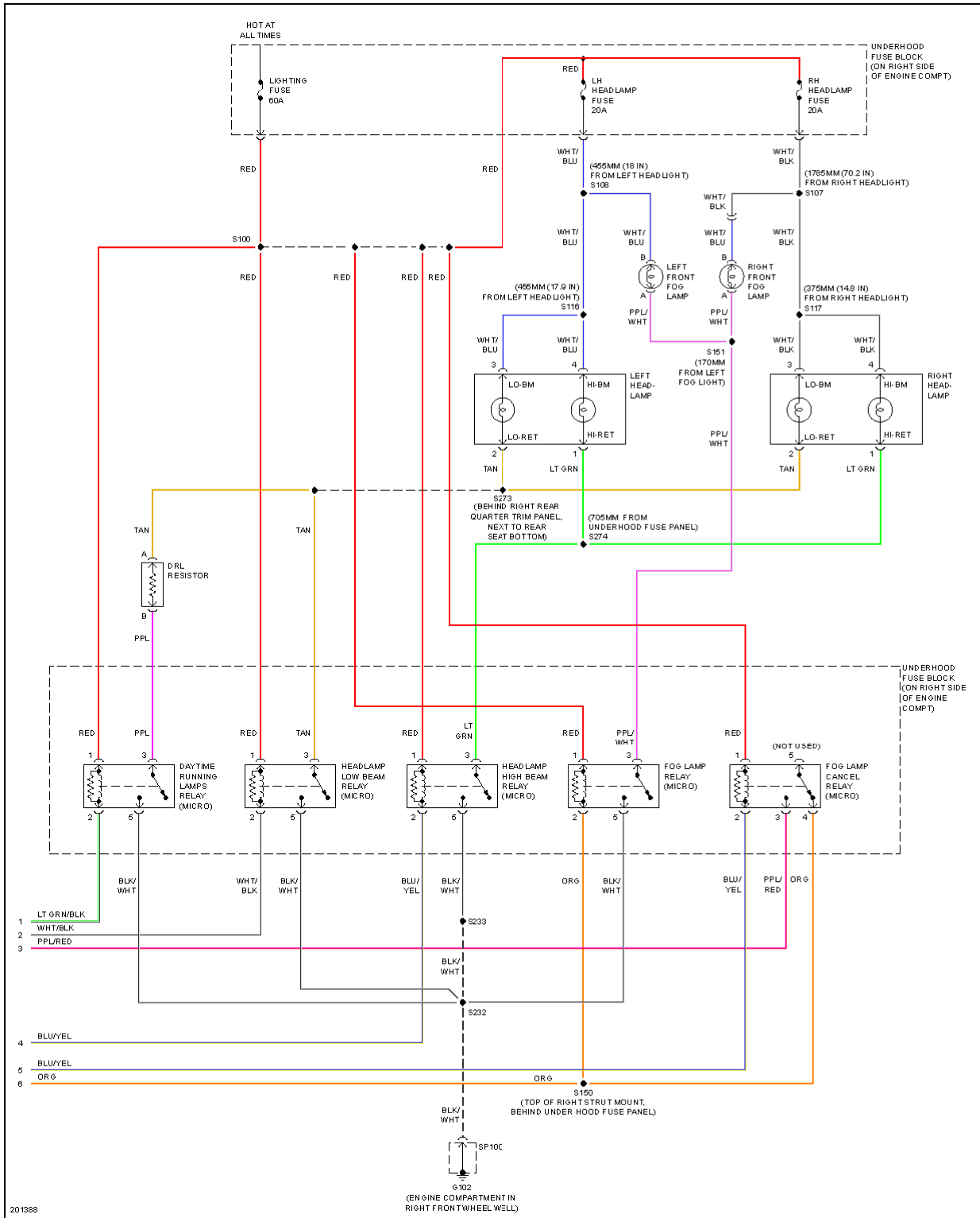
Fig. 21: Ground Distribution Circuit (2 of 3)



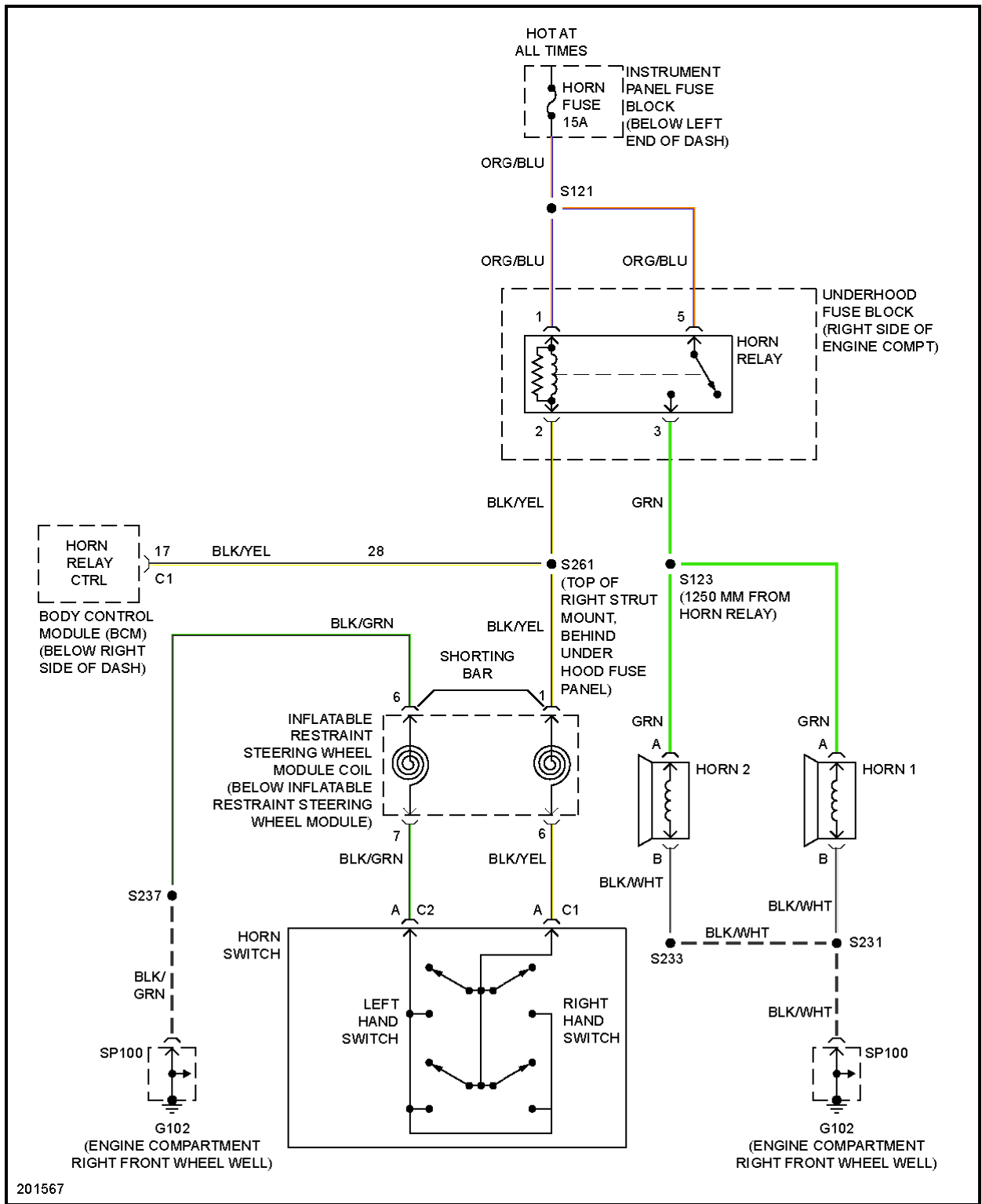
**Fig. 22: Ground Distribution Circuit (3 of 3)**



**Fig. 23: Headlights Circuit (1 of 2)**



**Fig. 24: Headlights Circuit (2 of 2)**



**Fig. 25: Horn Circuit**

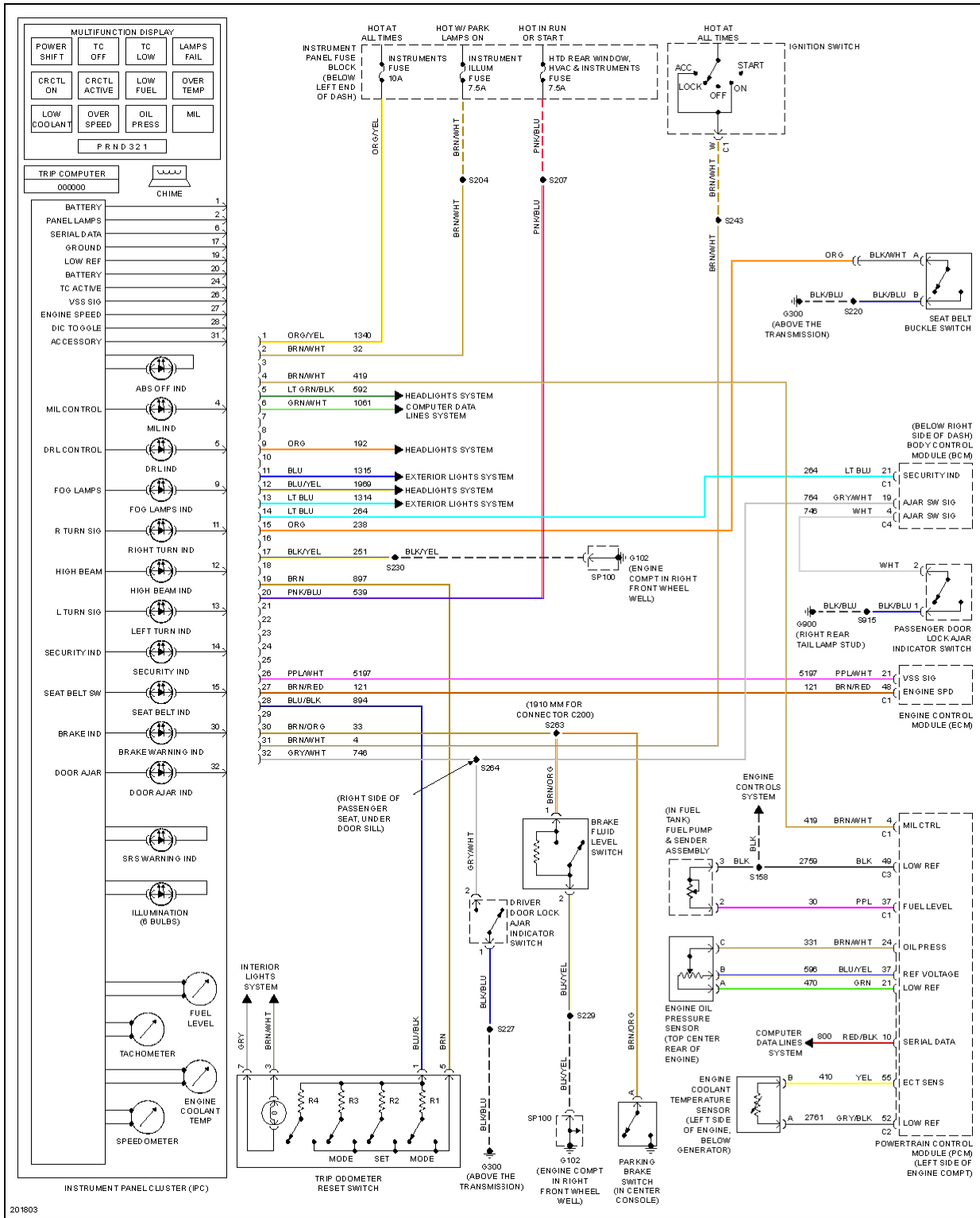
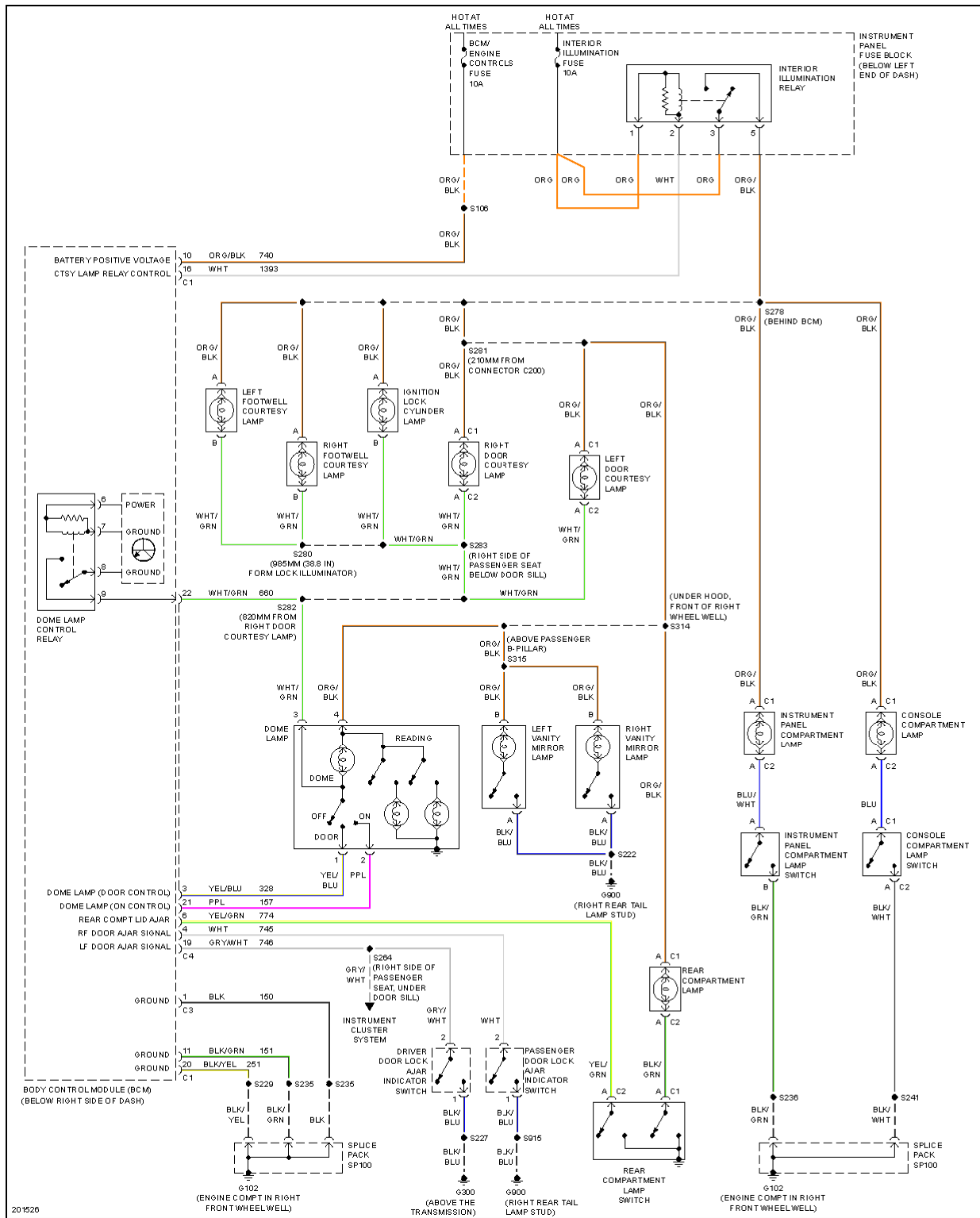
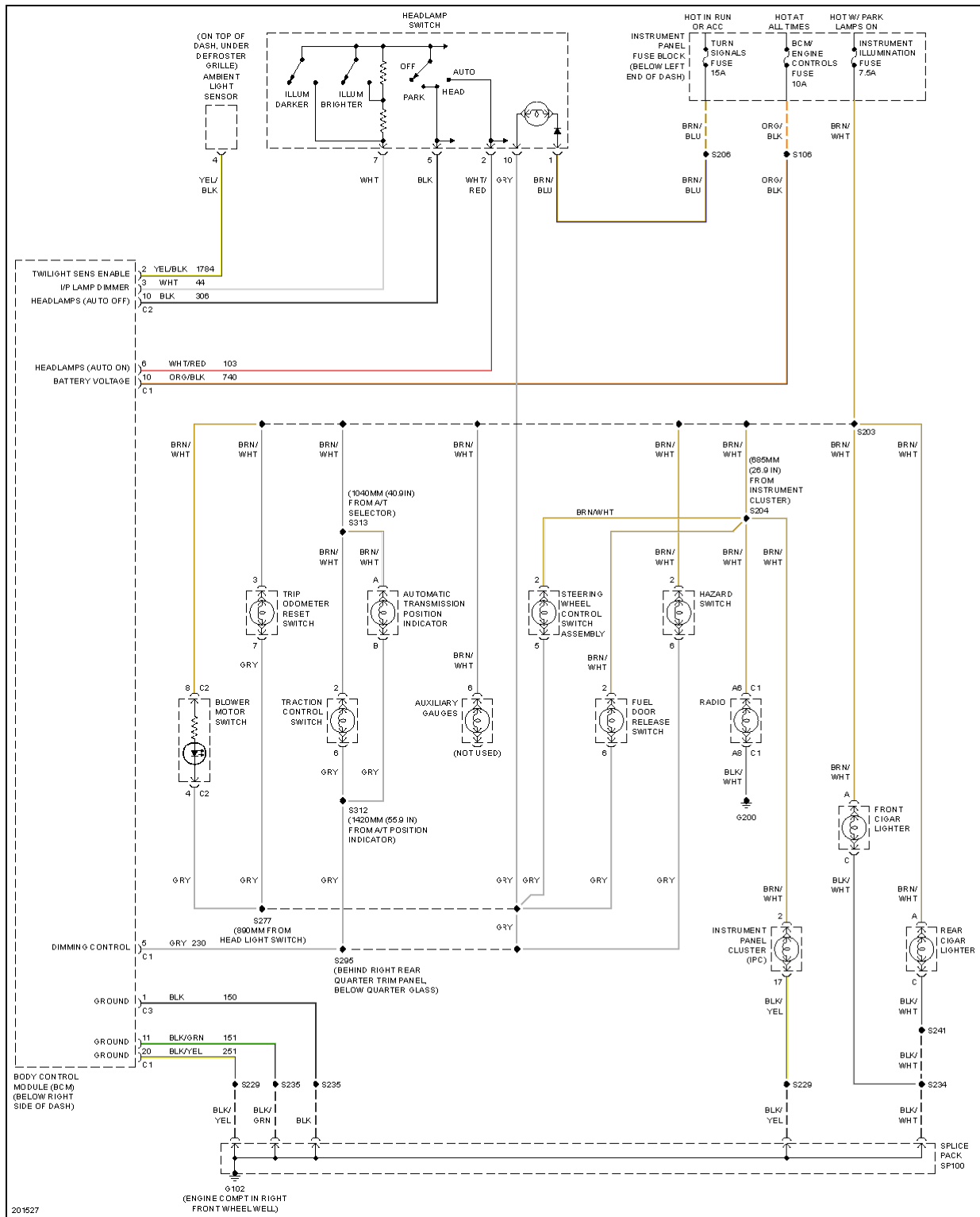


Fig. 26: Instrument Cluster Circuit

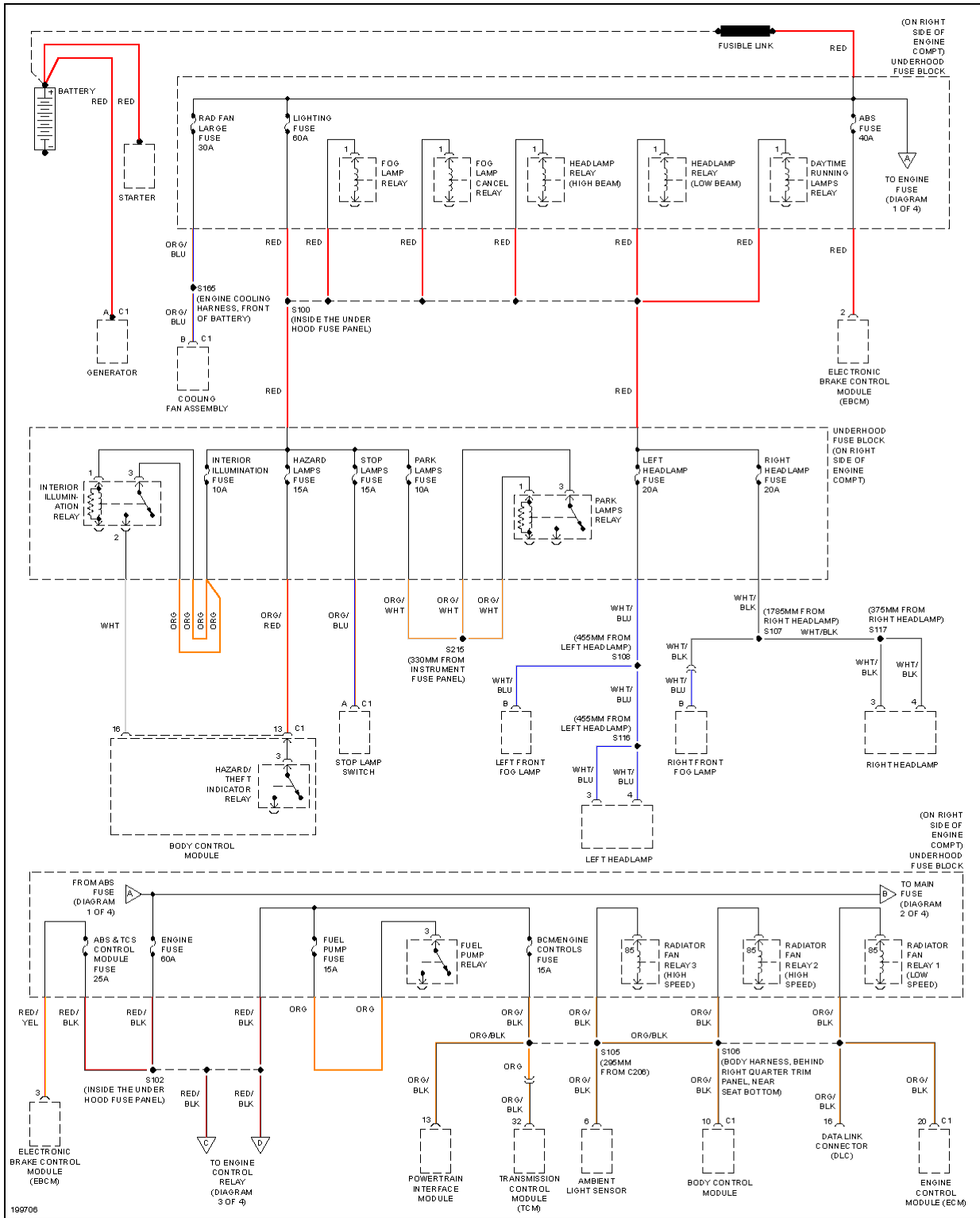


**Fig. 27: Courtesy Lamps Circuit**

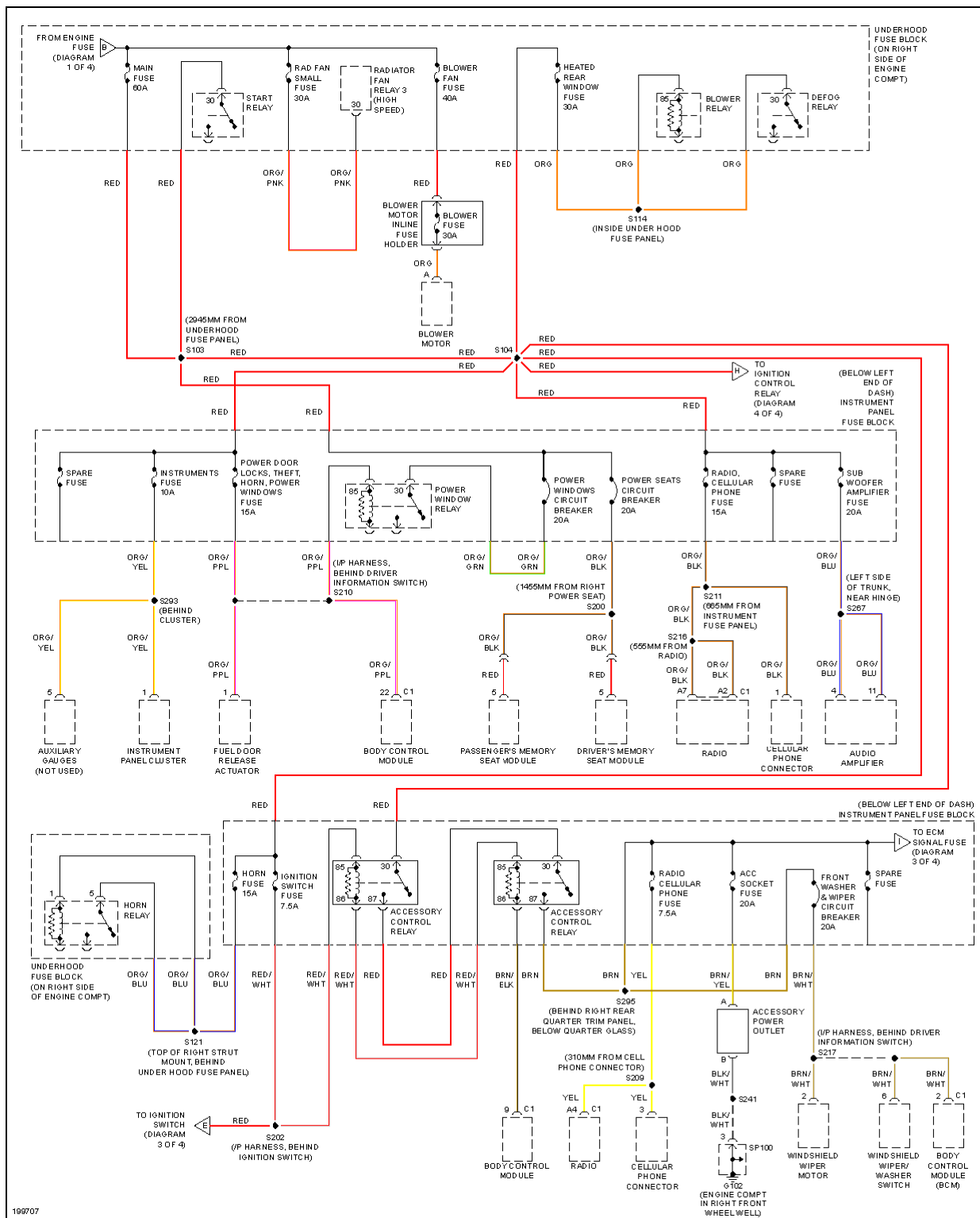


**Fig. 28: Instrument Illumination Circuit**

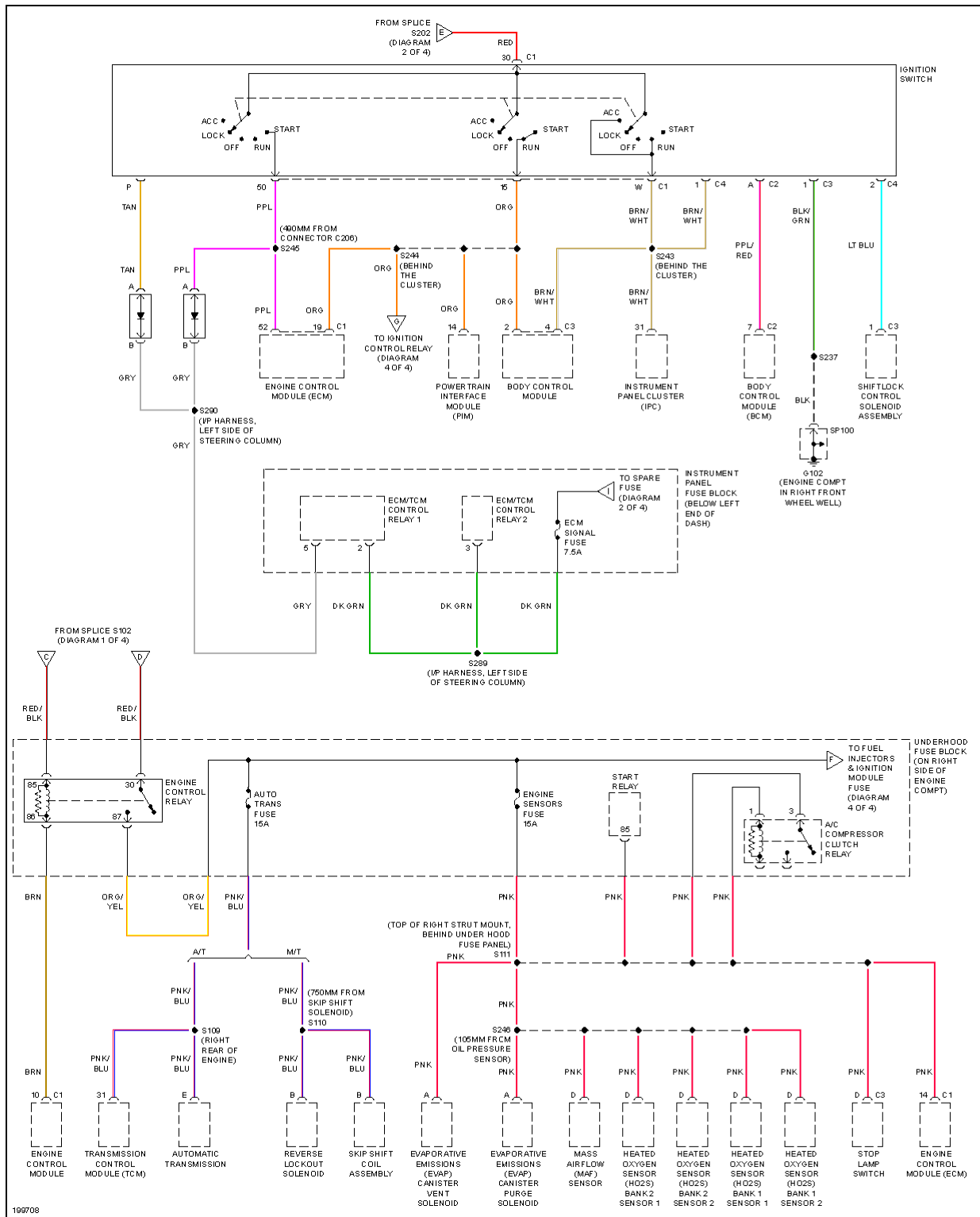




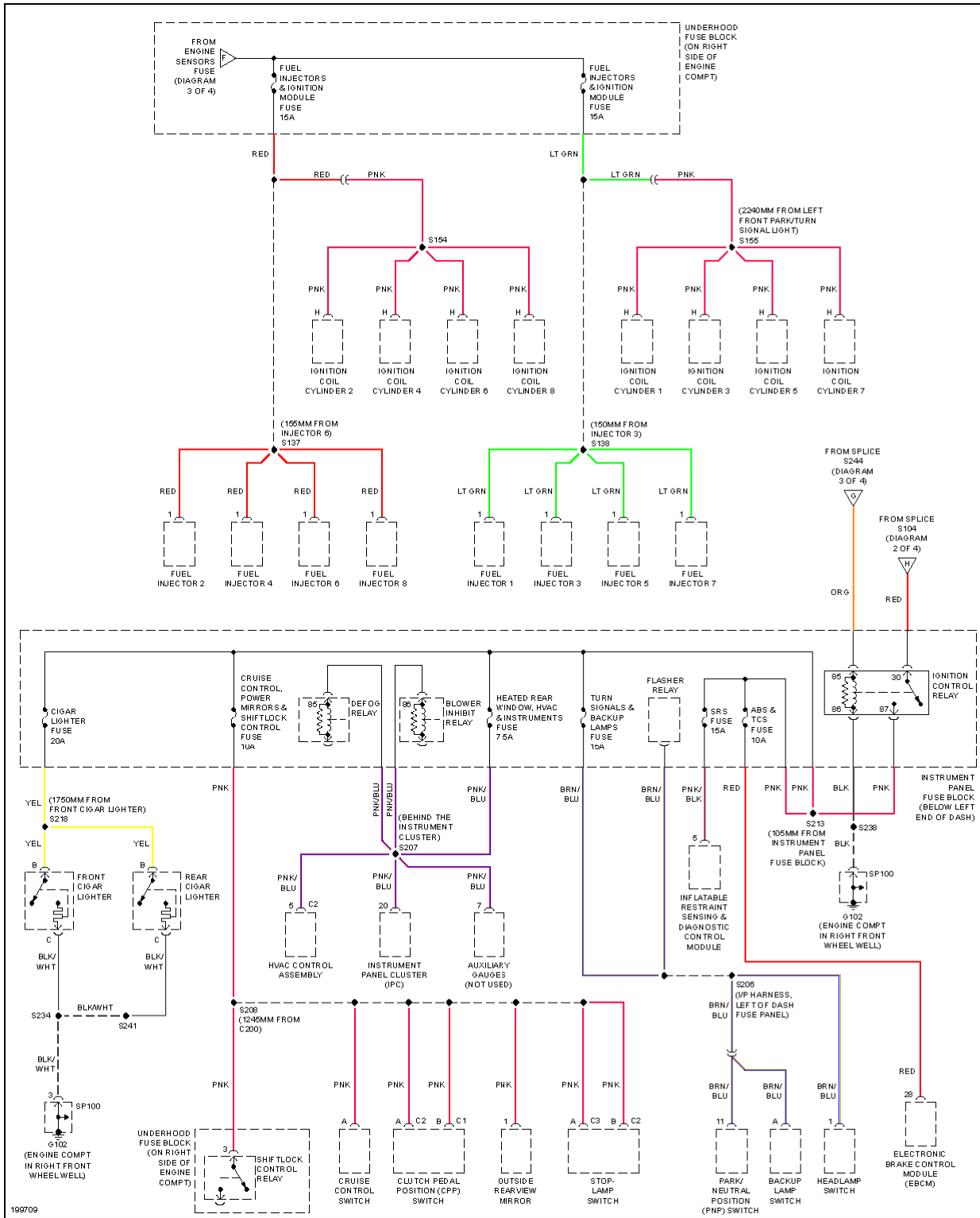
**Fig. 29: Power Distribution Circuit (1 of 4)**



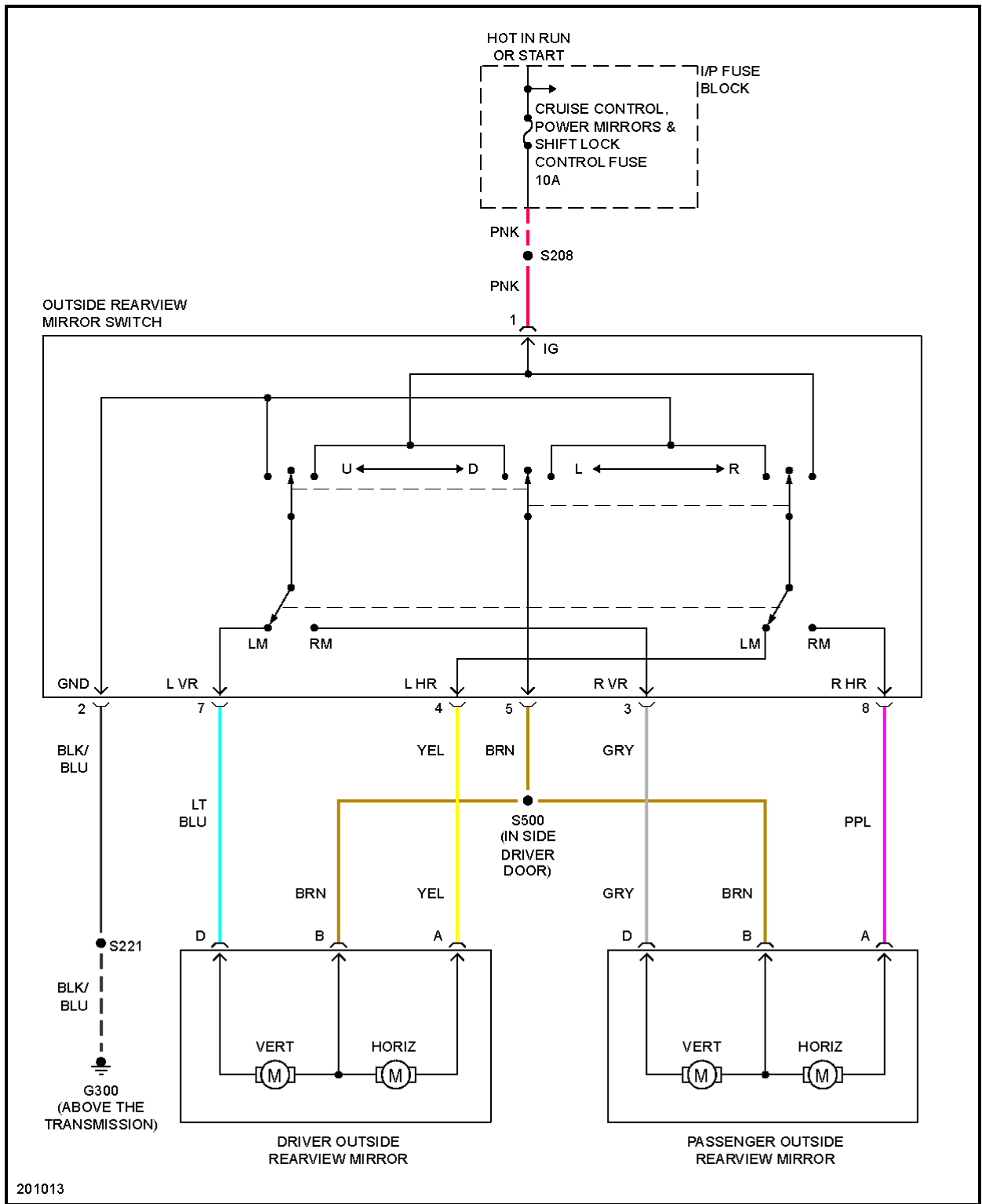
**Fig. 30: Power Distribution Circuit (2 of 4)**



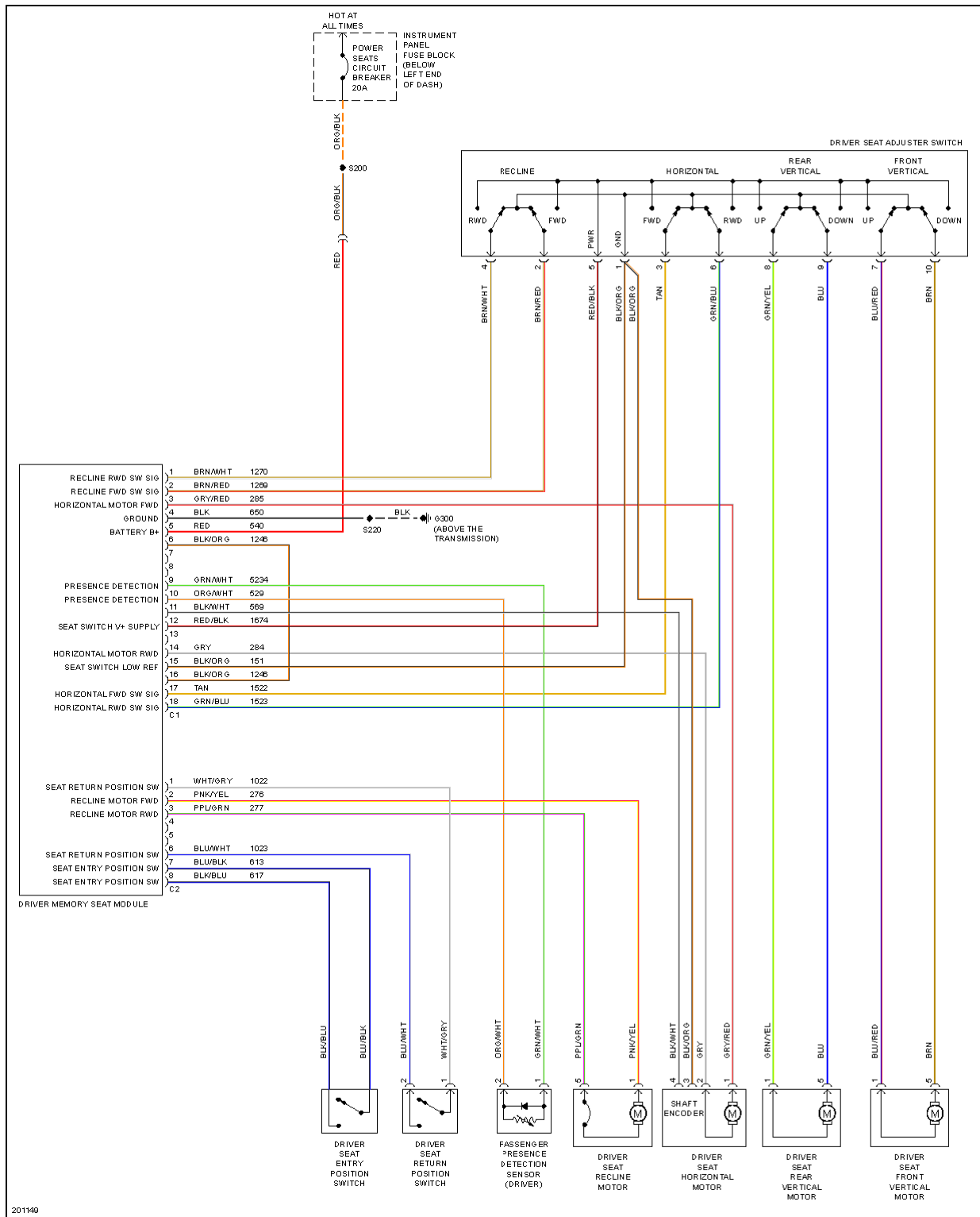
**Fig. 31: Power Distribution Circuit (3 of 4)**



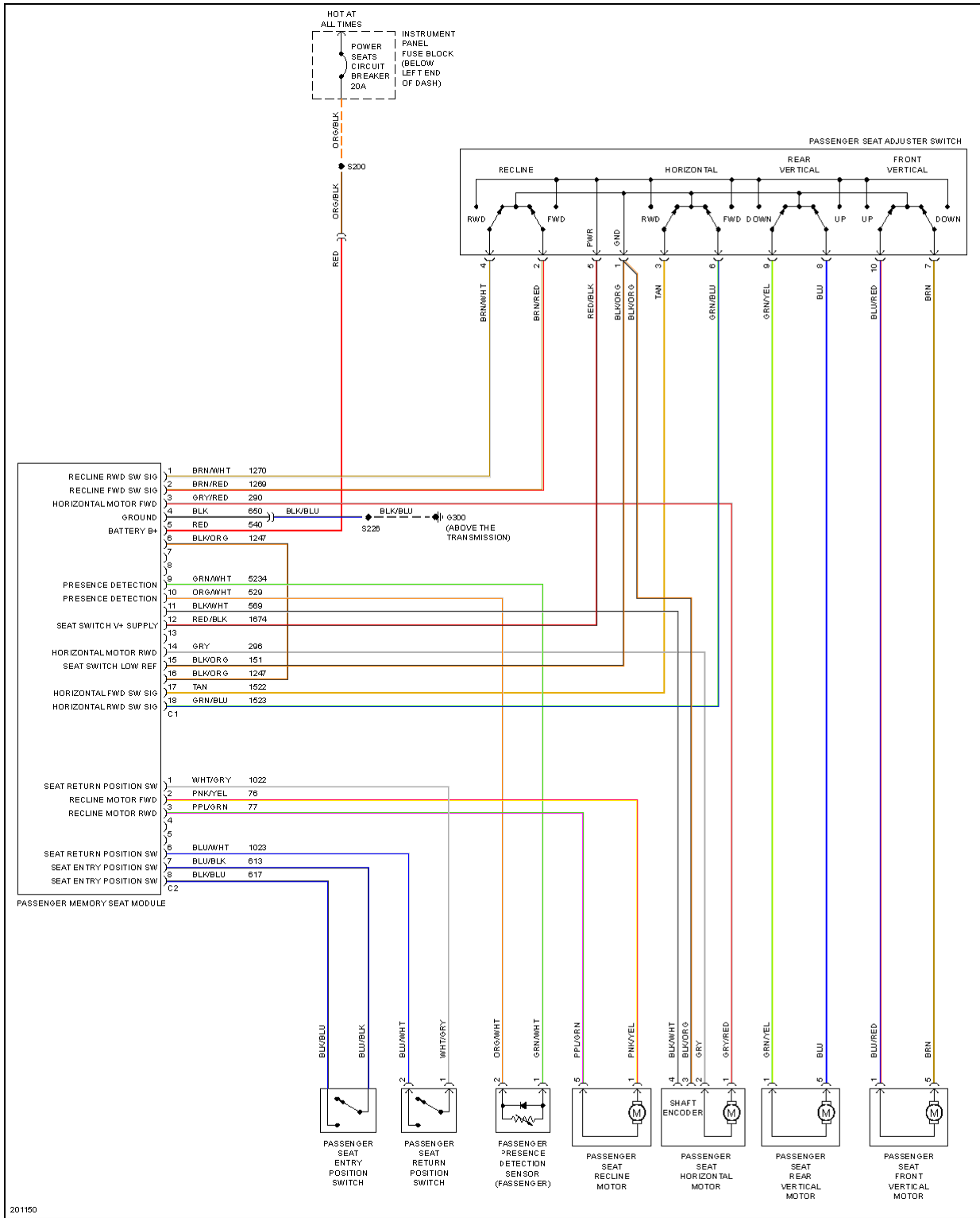
**Fig. 32: Power Distribution Circuit (4 of 4)**



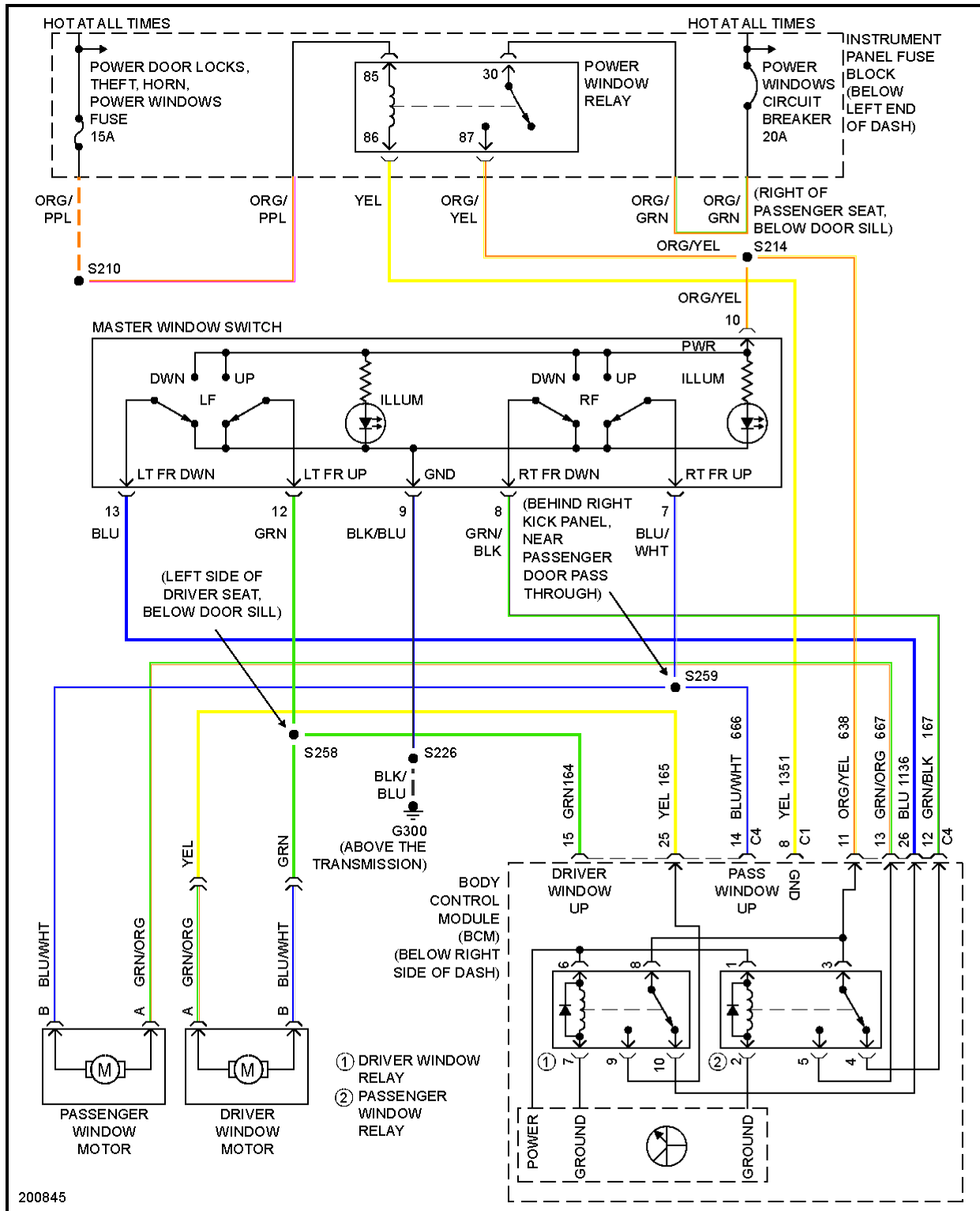
**Fig. 33: Power Mirrors Circuit**



**Fig. 34: Driver Power Seat Circuit**

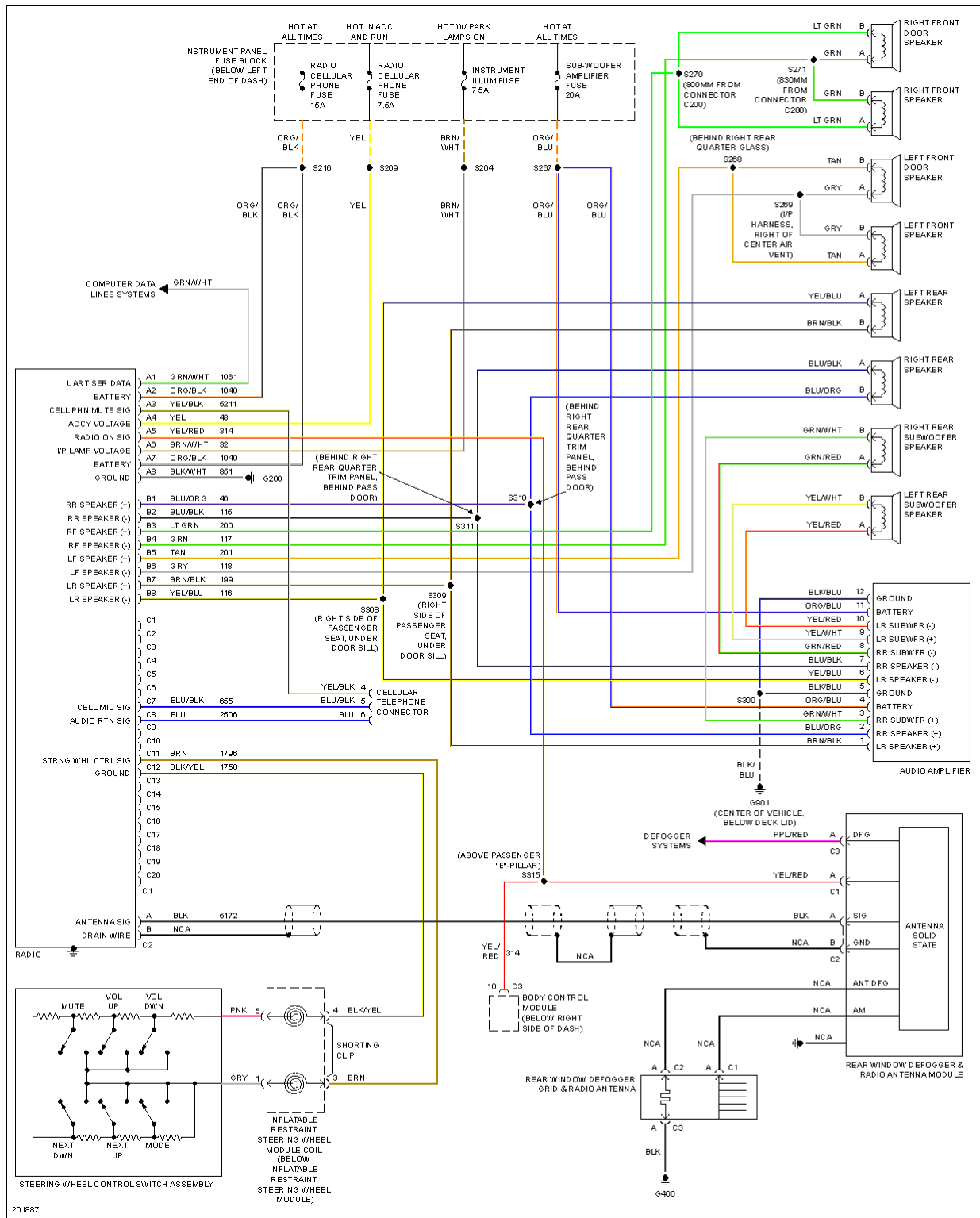


**Fig. 35: Passenger Power Seat Circuit**

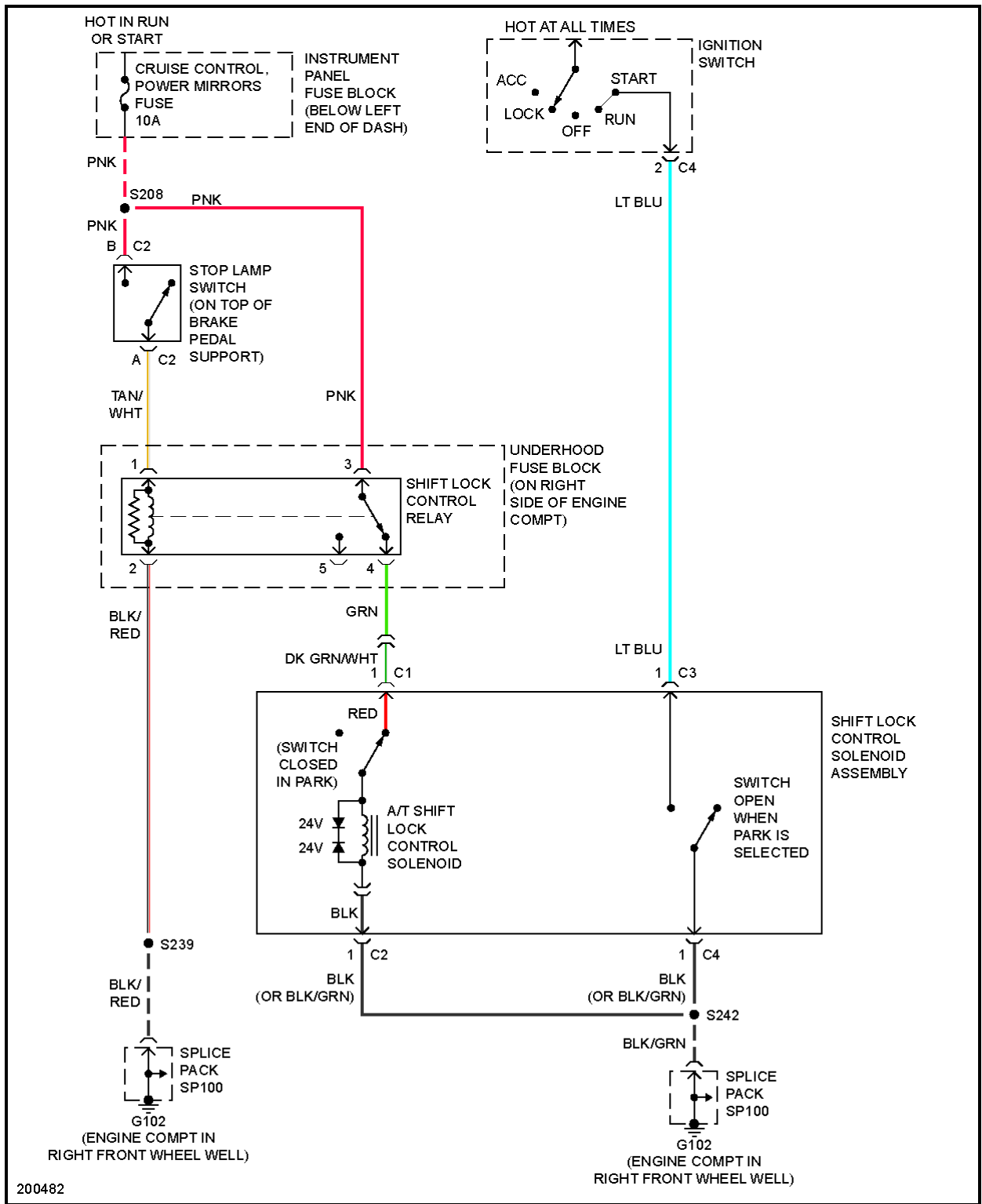


**Fig. 36: Power Windows Circuit**

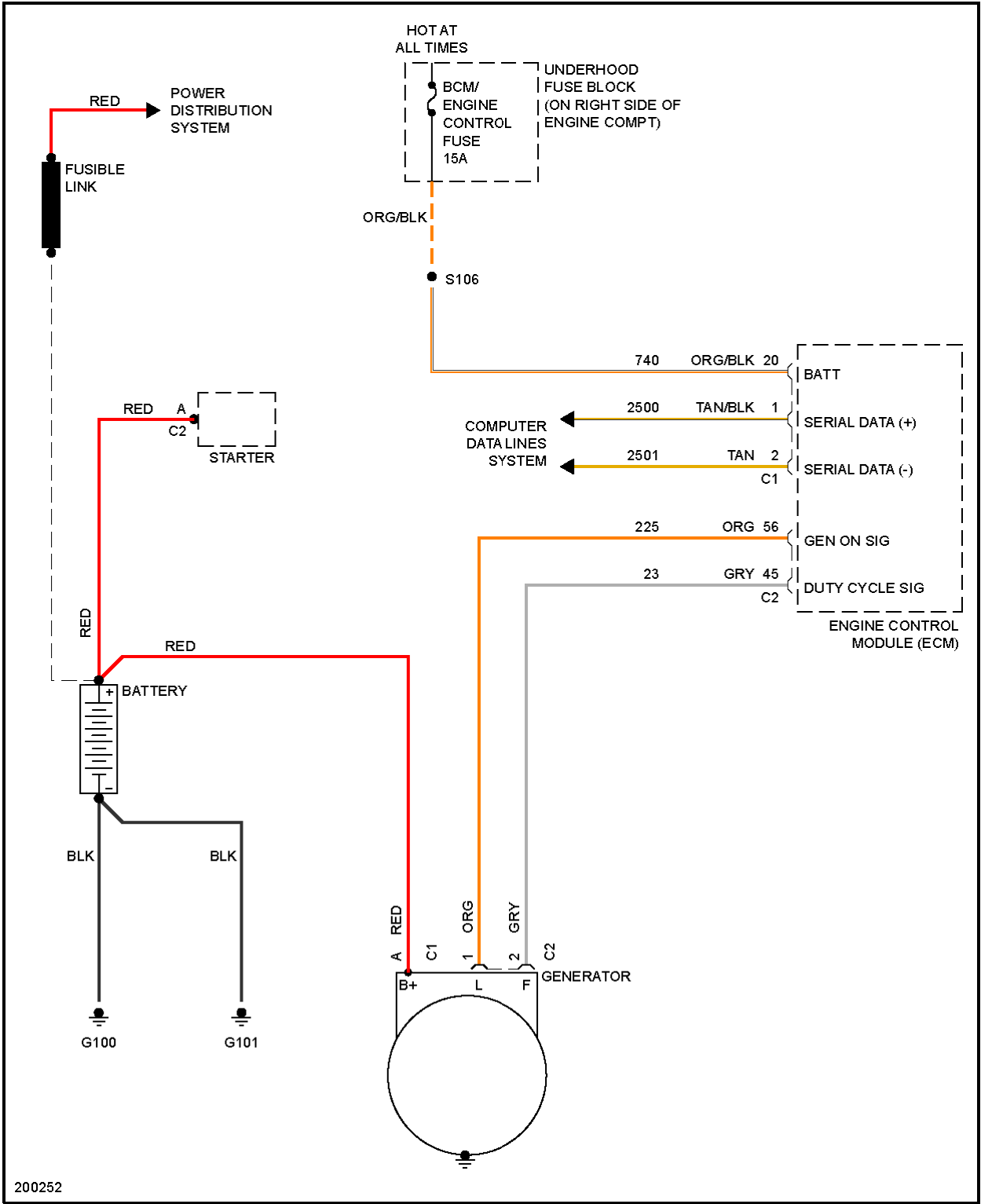




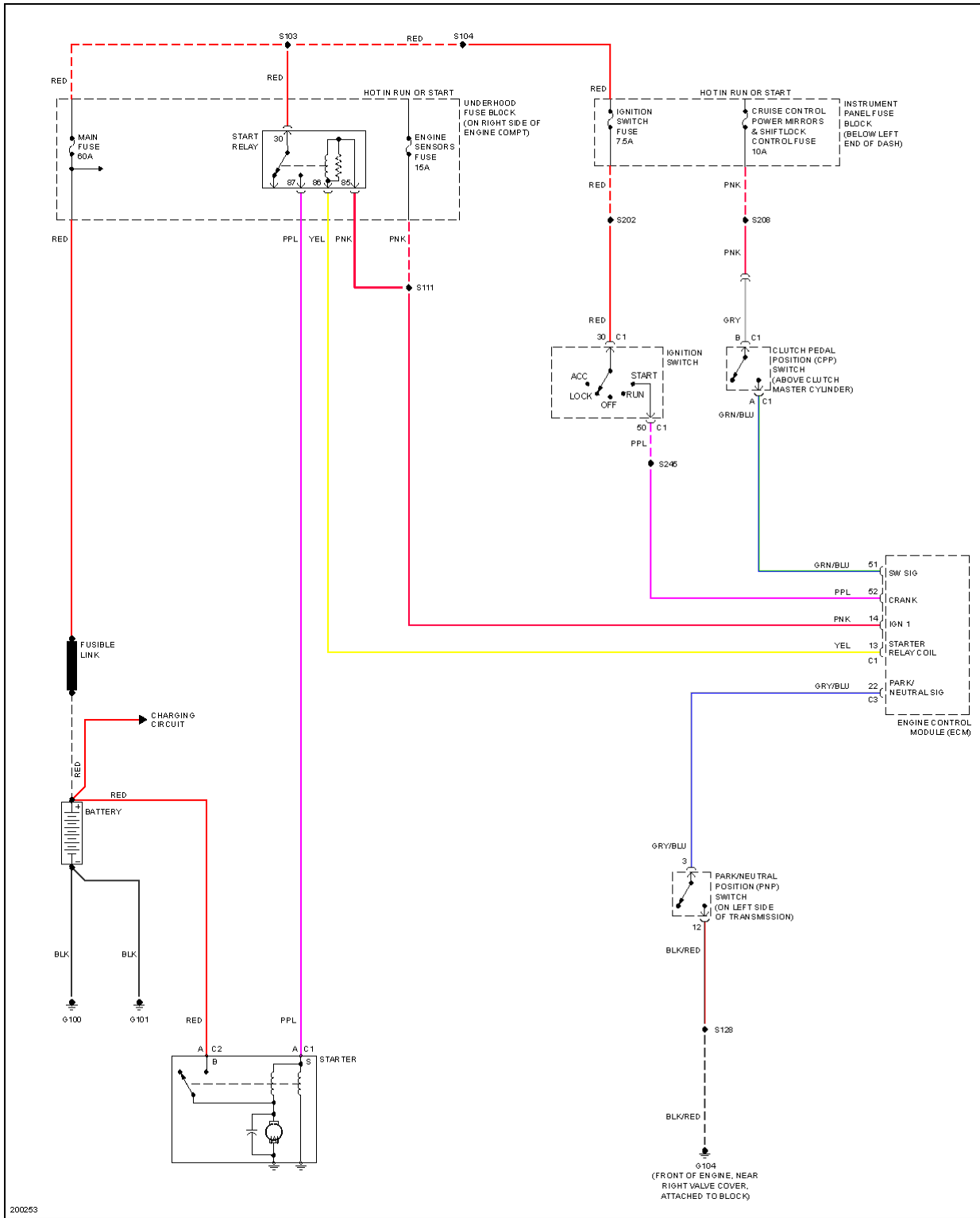
**Fig. 37: Radio Circuit**



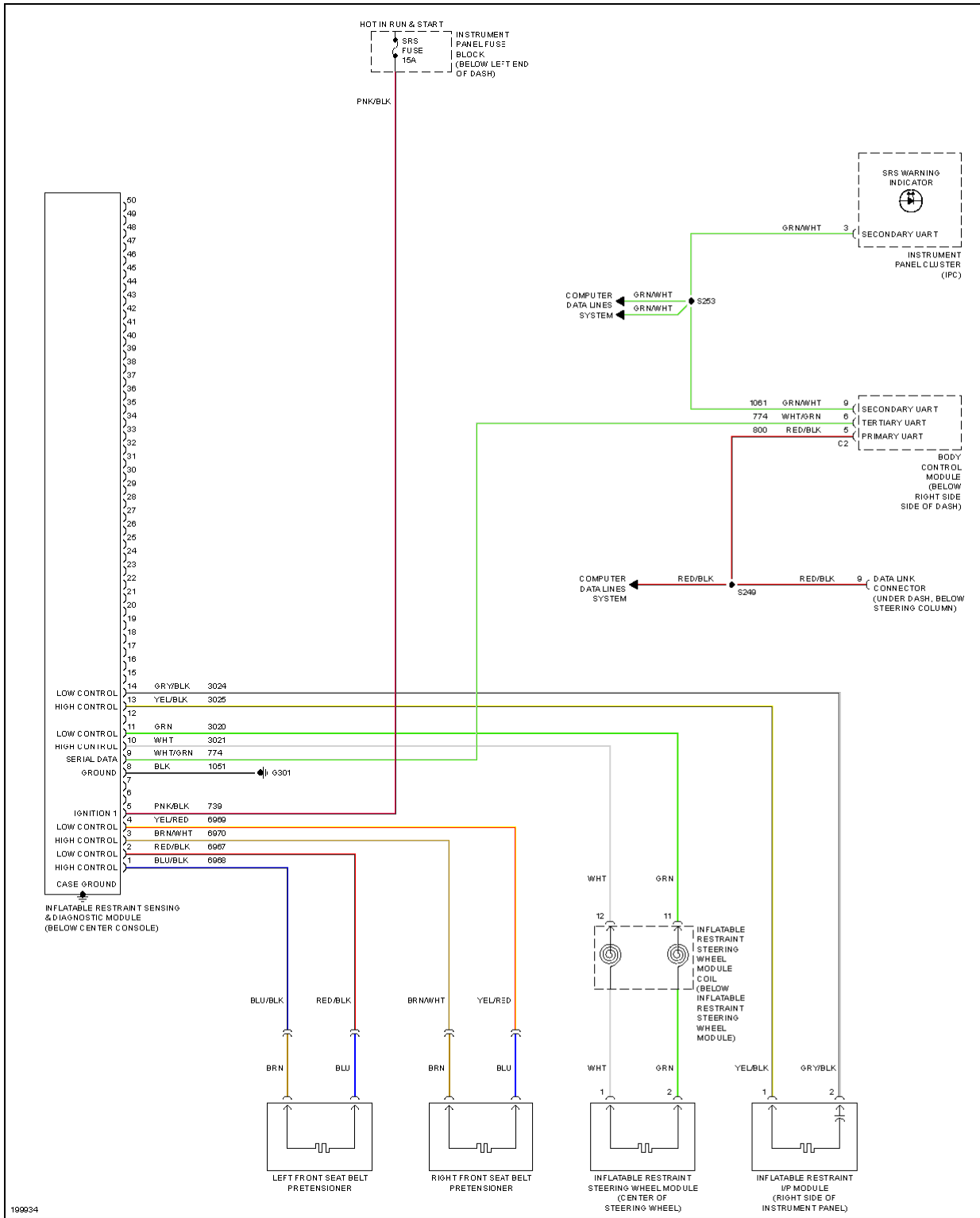
**Fig. 38: Shift Interlock Circuit**



**Fig. 39: Charging Circuit**



**Fig. 40: Starting Circuit**



**Fig. 41: Supplemental Restraints Circuit**

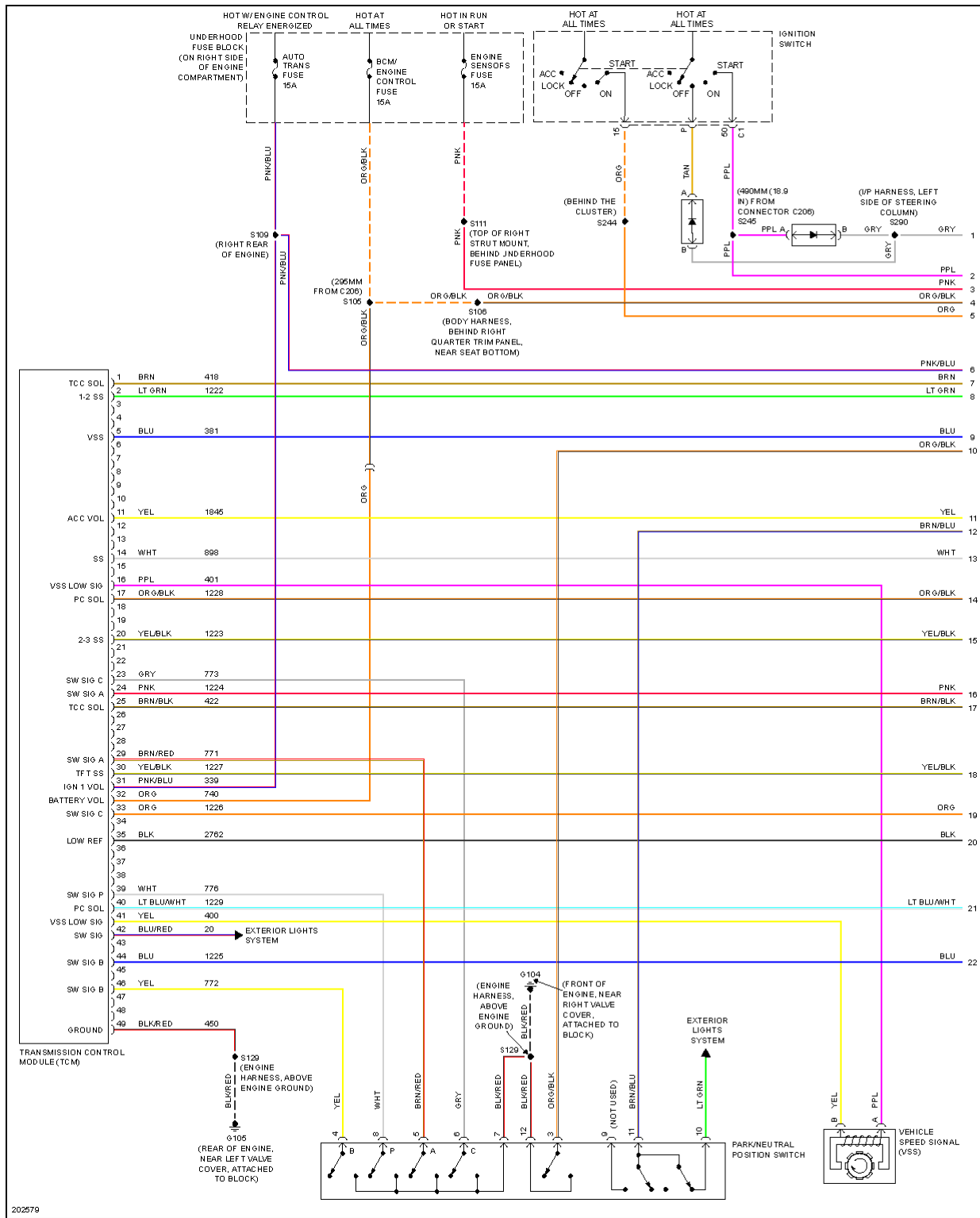


Fig. 42: A/T Circuit (1 of 2)

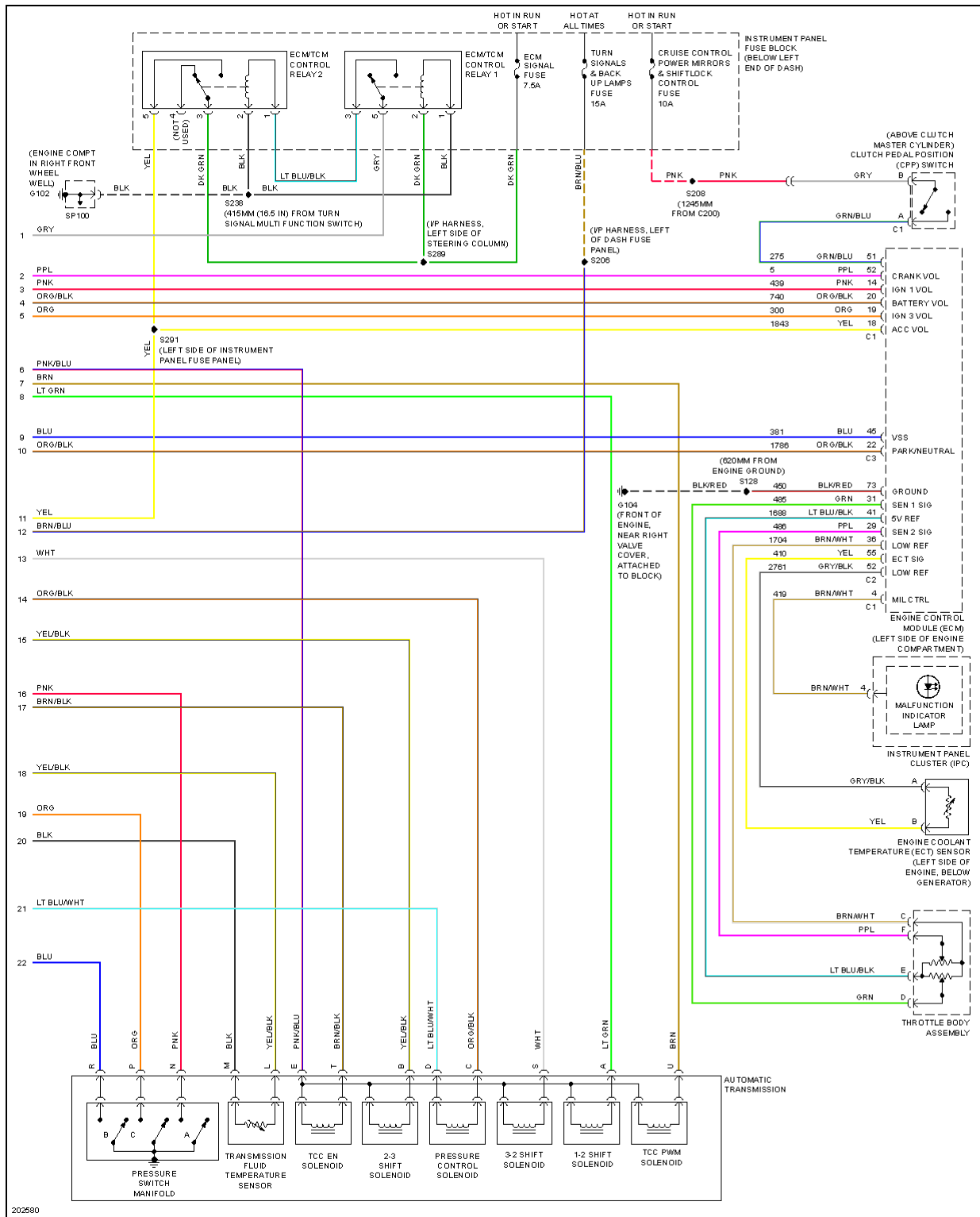


Fig. 43: A/T Circuit (2 of 2)

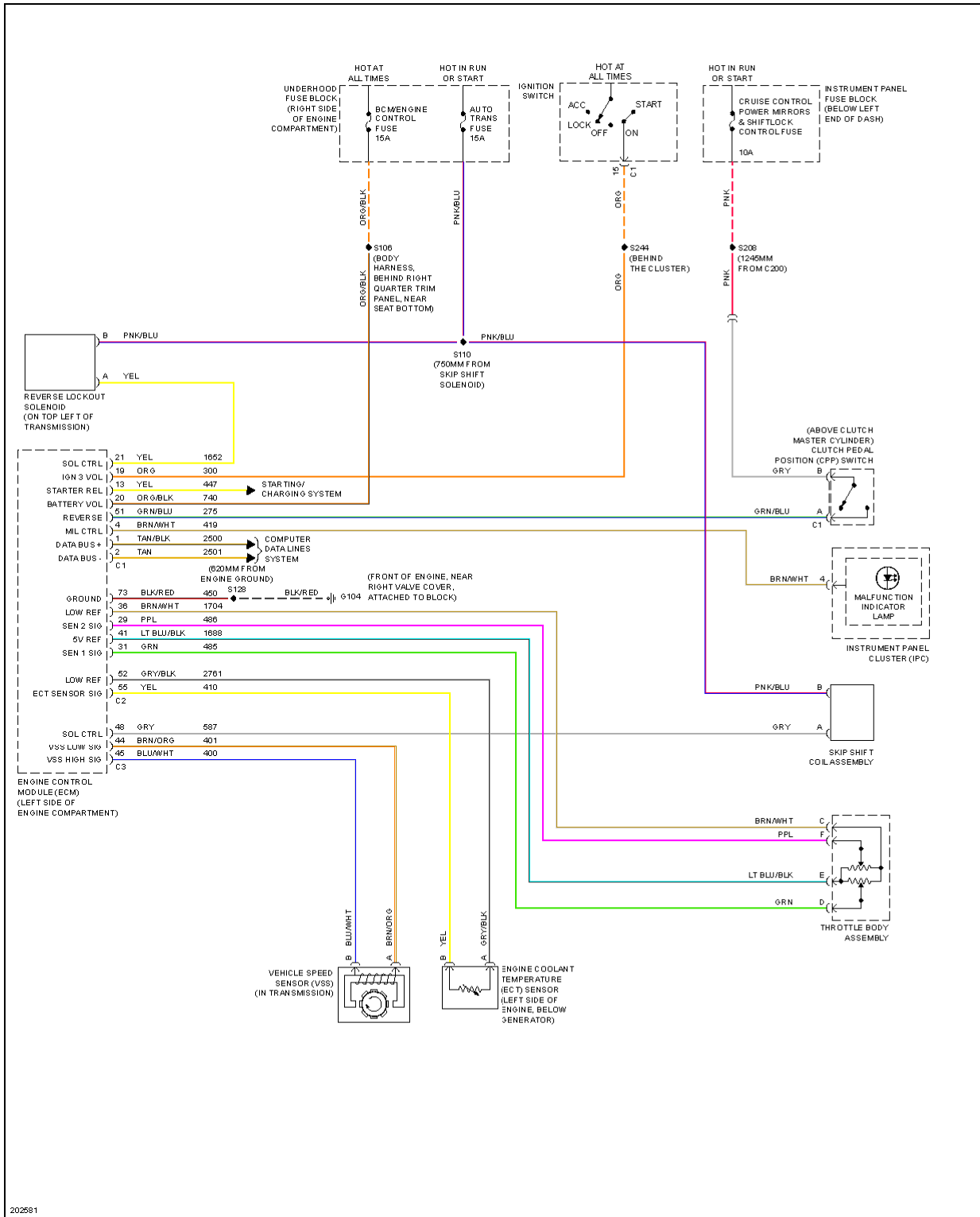
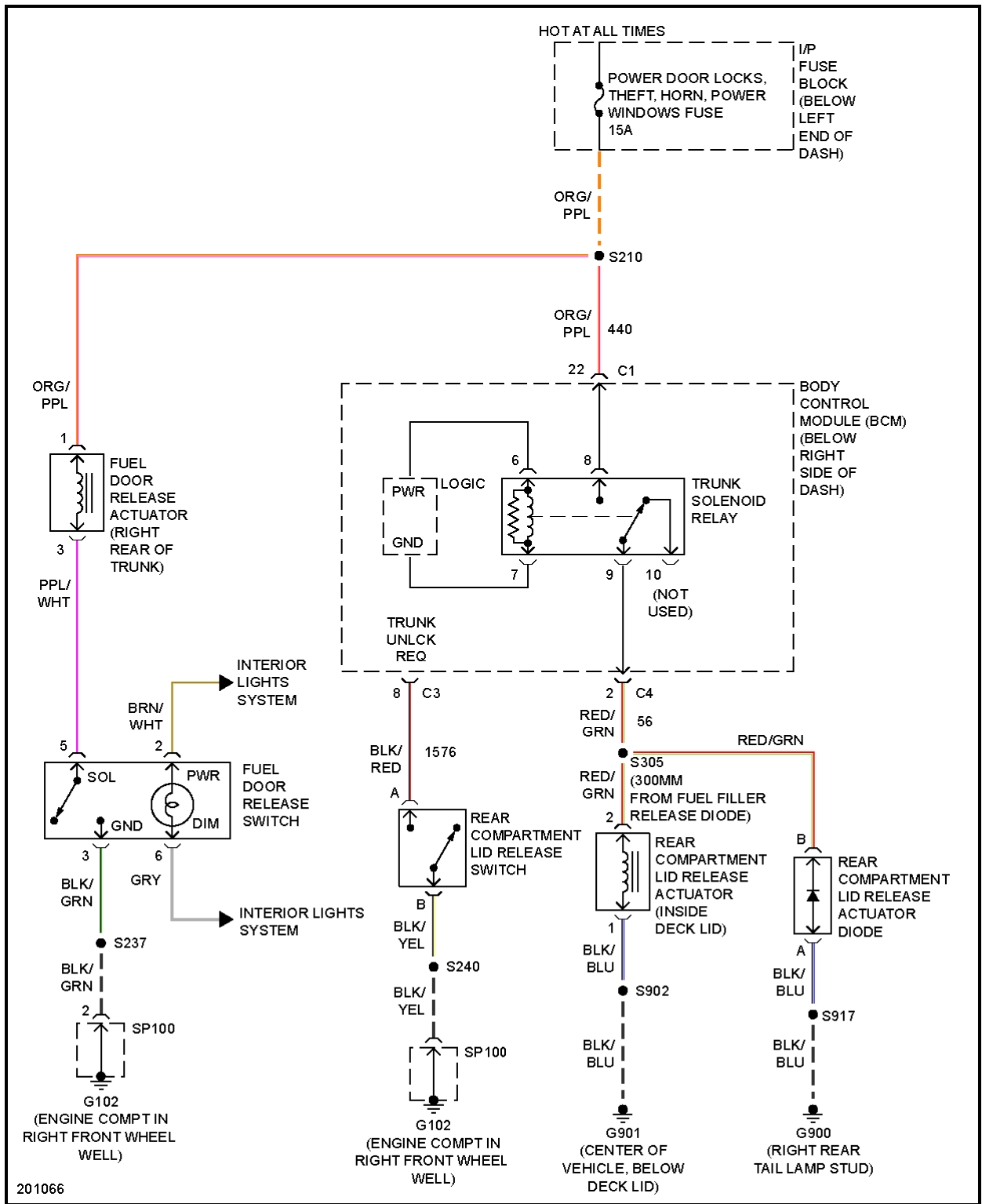
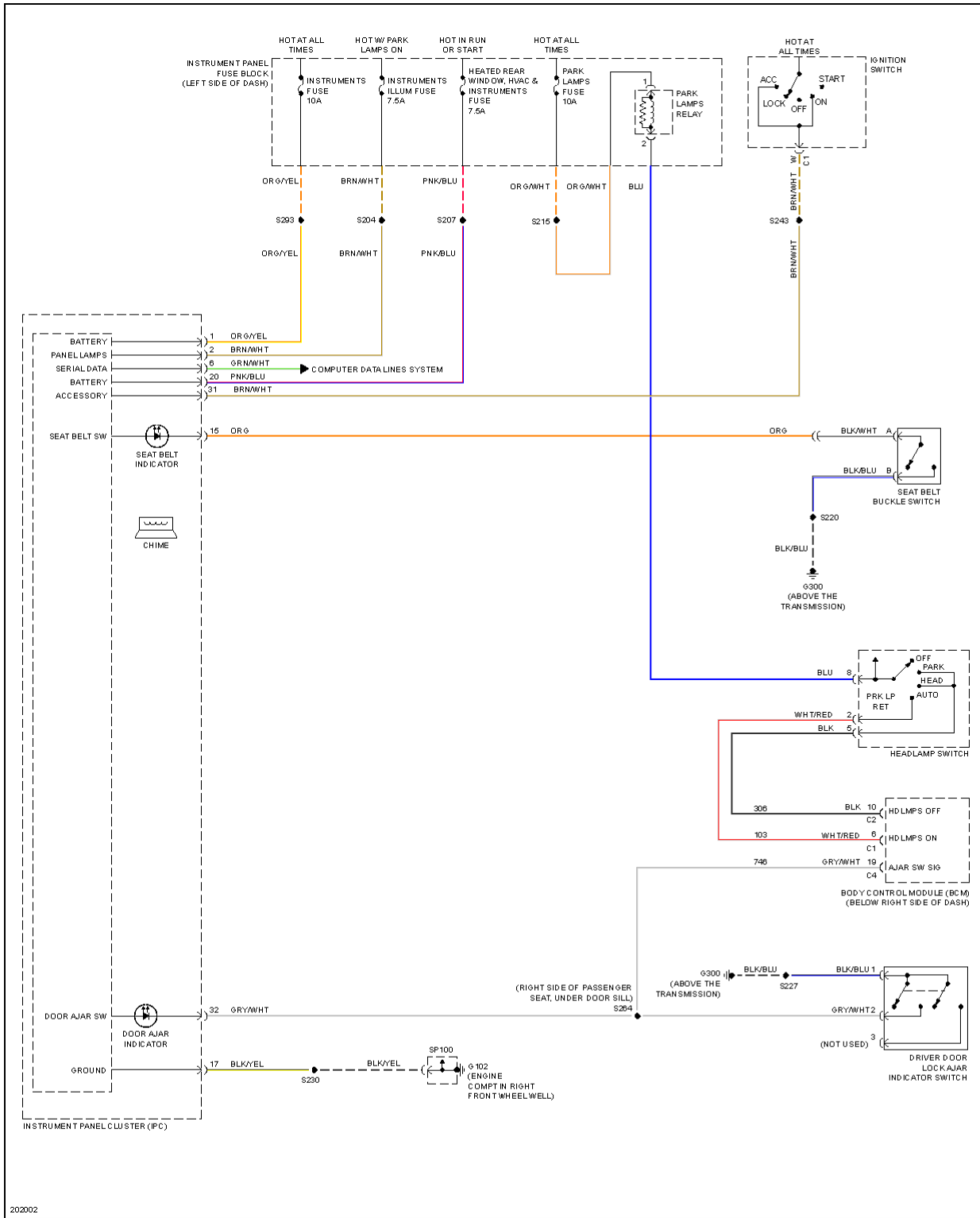


Fig. 44: M/T Circuit

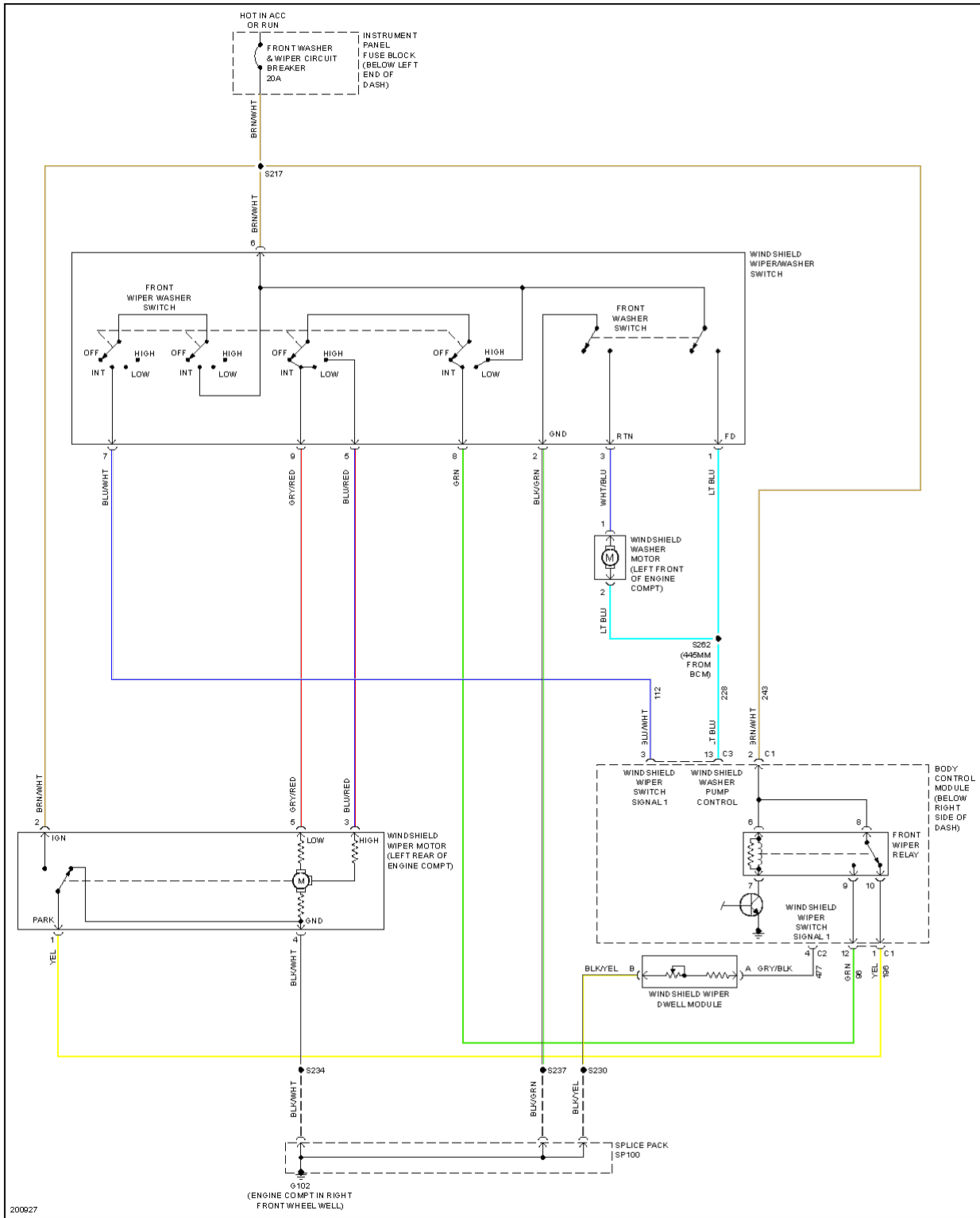




**Fig. 45: Trunk, Tailgate, Fuel Door Circuit**



**Fig. 46: Warning Systems Circuit**



**Fig. 47: Wiper/Washer Circuit**