

<- Back

Forward ->

Document ID# 235430
1998 Pontiac Firebird

Print

Front Caster and Camber Adjustment

Tools Required

[J 38658](#) Caster/Camber Adjusting Tool

1. Jounce the front bumper three times to allow the vehicle to return to normal height before making any adjustments in the caster.
2. Raise and suitably support the vehicle. Refer to [Lifting and Jacking the Vehicle](#) in General Information.
3. Loosen the front lower control arm nuts.

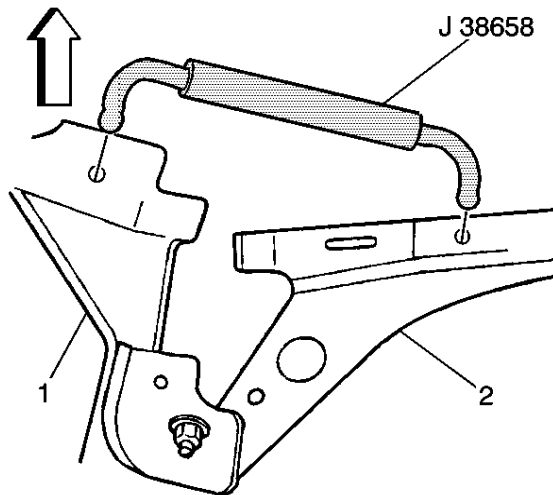

4. Install the [J 38658](#) to the slot holes in the lower control arm (2) and front crossmember (1).
5. Adjust the camber by rotating the turnbuckle on the [J 38658](#) .
 - A. Rotating the turnbuckle clockwise will increase the camber.
 - B. Rotating the turnbuckle counterclockwise will decrease the camber.

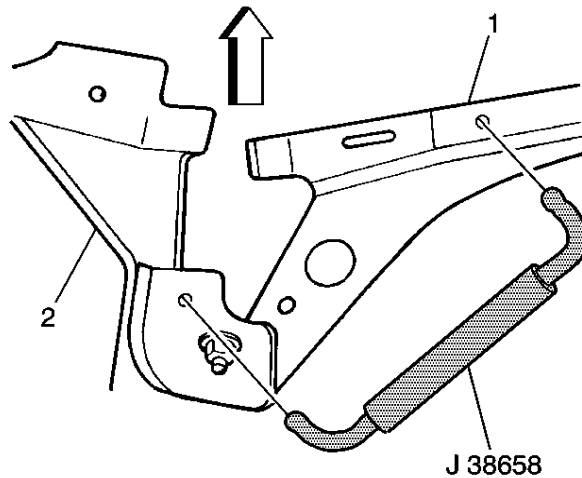

6. Install the [J 38658](#) to the slot holes in the lower control arm (1) and front crossmember (2).
 - A. Rotating the turnbuckle clockwise will increase the caster.
 - B. Rotating the turnbuckle counterclockwise will decrease the caster.
7. Adjust the caster by rotating the turnbuckle on the [J 38658](#).
8. Remove the [J 38658](#) from the slot holes.

Notice

Use the correct fastener in the correct location. Replacement fasteners must be the correct part number for that application. Fasteners requiring replacement or fasteners requiring the use of thread locking compound or sealant are identified in the service procedure. Do not use paints, lubricants, or corrosion inhibitors on fasteners or fastener joint surfaces unless specified. These coatings affect fastener torque and joint clamping force and may damage the fastener. Use the correct tightening sequence and specifications when installing fasteners in order to avoid damage to parts and systems.

9. Tighten the front lower control arm nuts. **Tighten**

Tighten the front lower control arm nuts to 100 N·m (74 lb ft).

10. Lower the vehicle. Refer to [Lifting and Jacking the Vehicle](#) in General Information.

[<- Back](#)

[Forward ->](#)

Document ID# 235430
1998 Pontiac Firebird

[Print](#)